



Transport



Contents

Click on the desired sub-segment to go directly to the page

	catalogue pg. nos	pdf pg. nos
Transport		
Bus windows	163	3
Bus structurals	173	13
Floorings	178	18
Truck body structurals	182	22
Rail coach	188	28

Bus windows

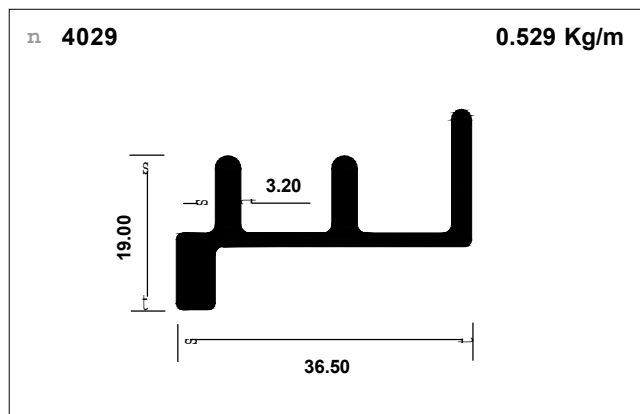
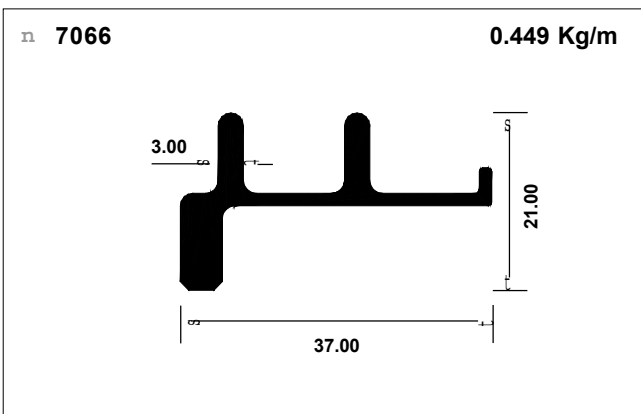
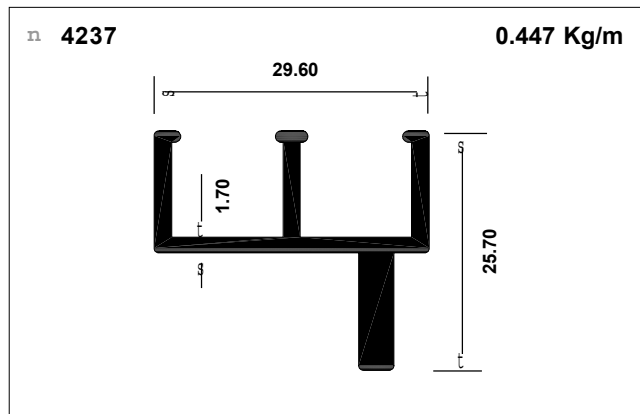
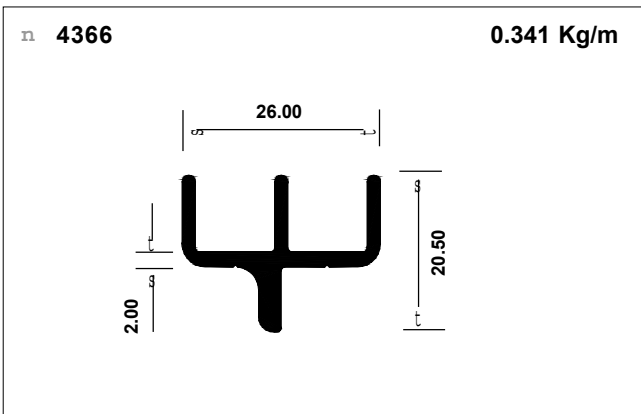
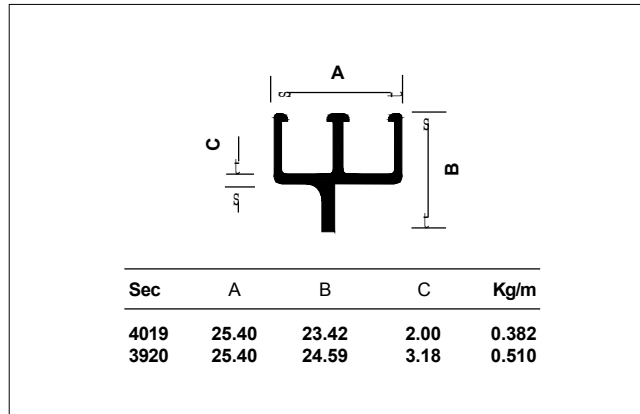
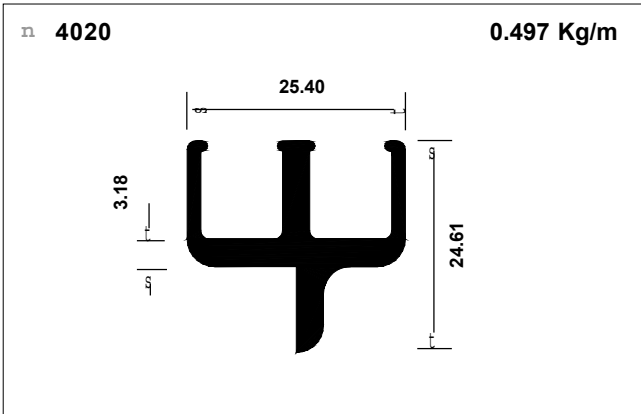
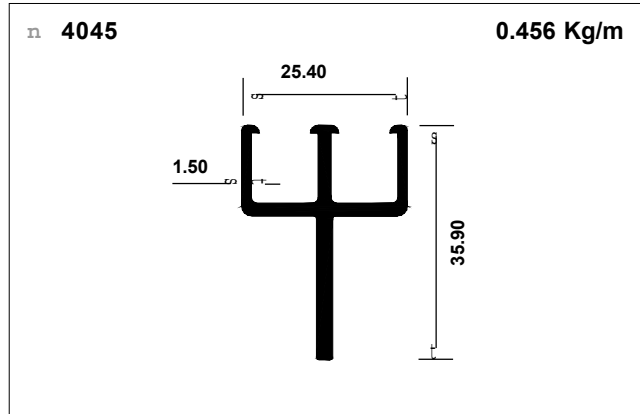
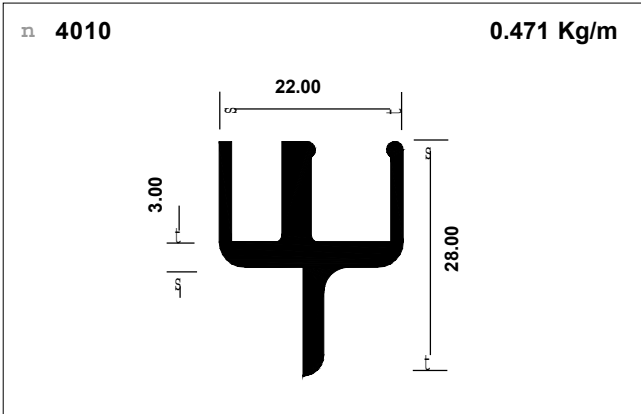

Bus windows

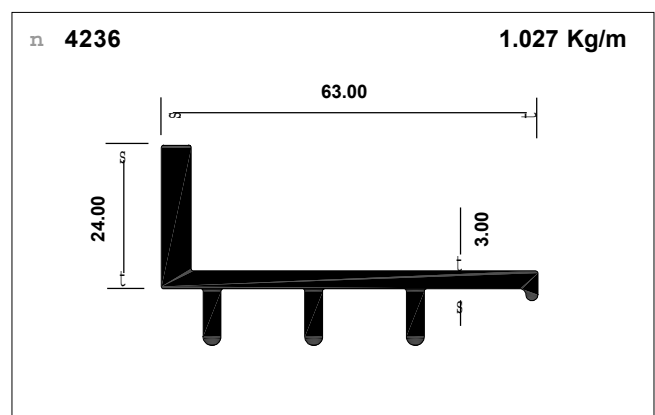
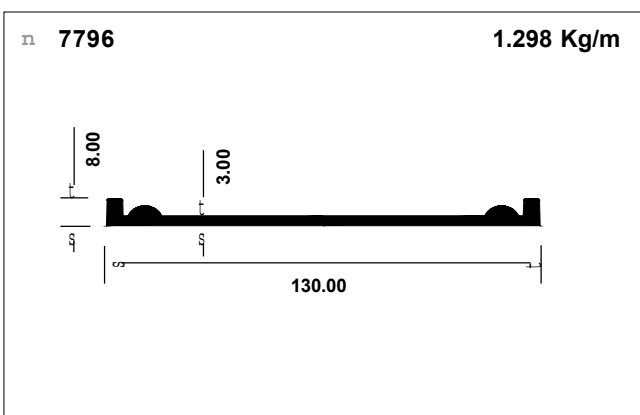
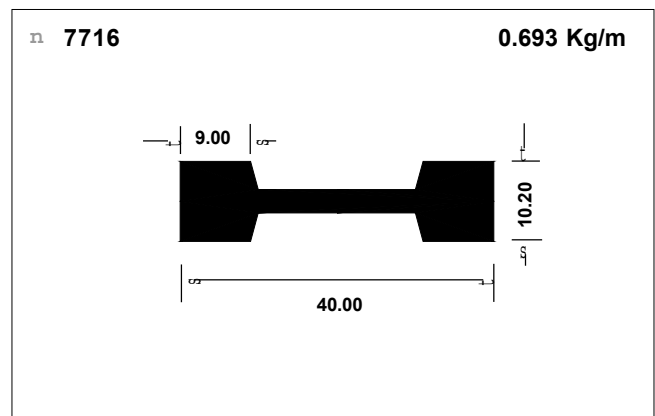
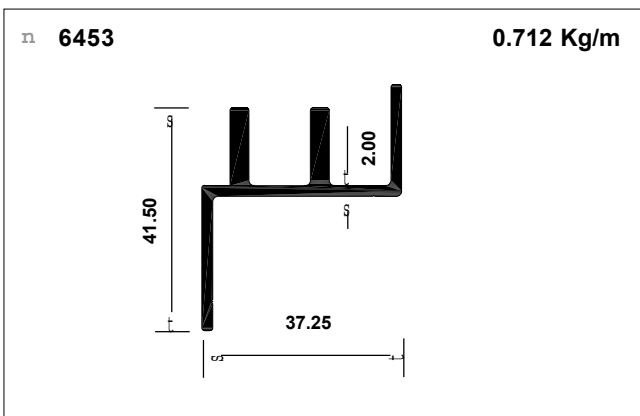
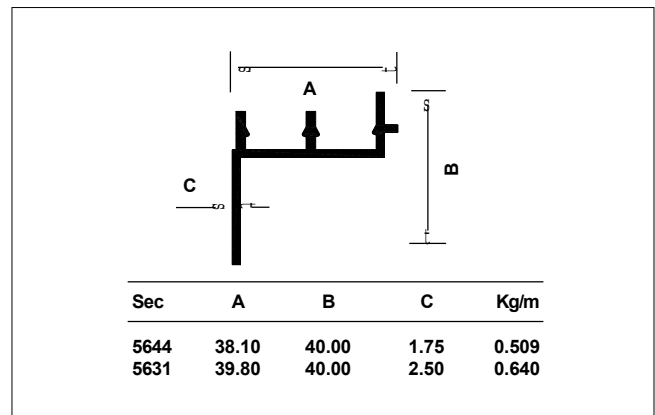
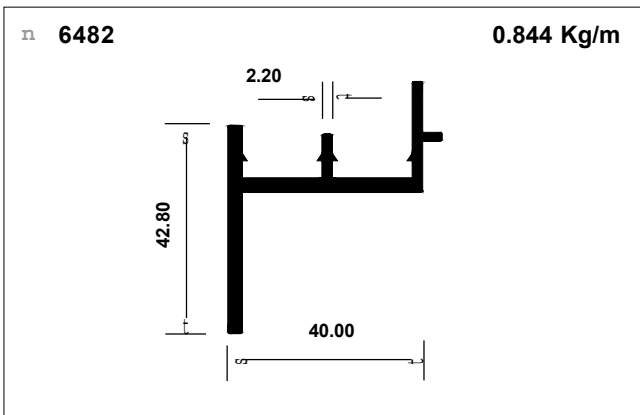
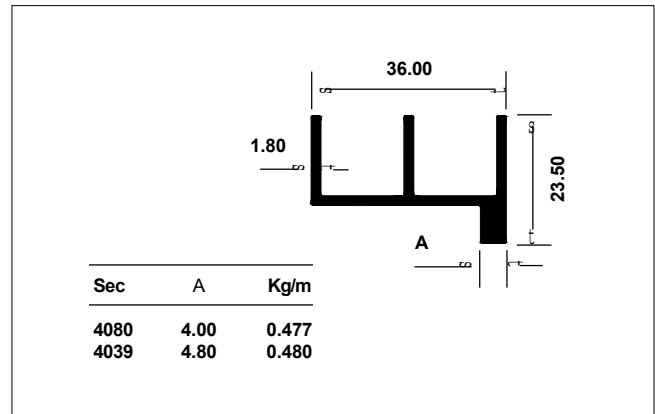
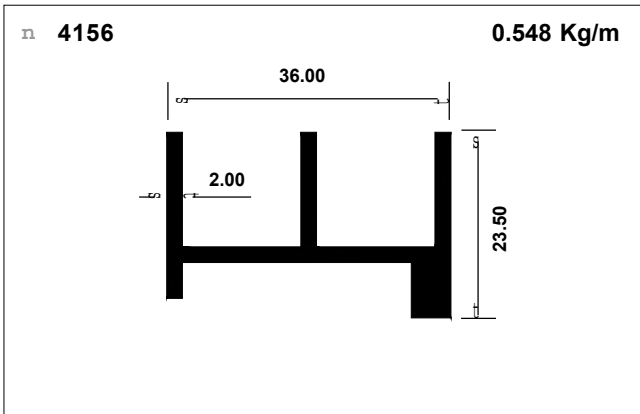

Bus windows

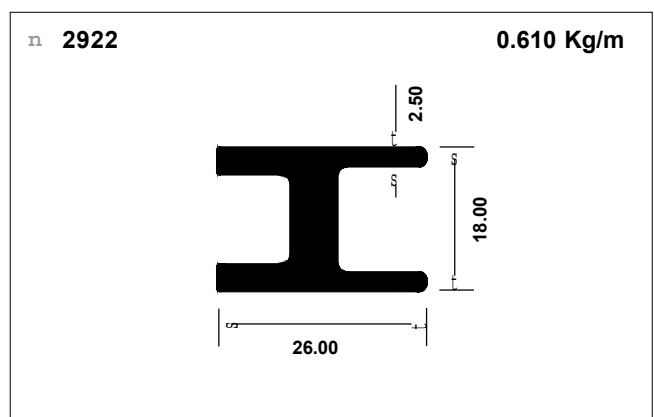
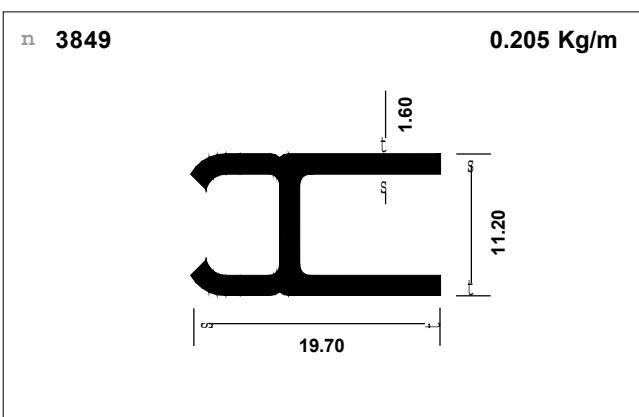
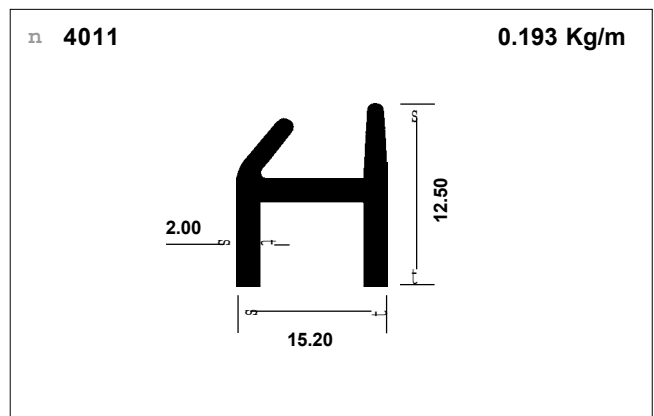
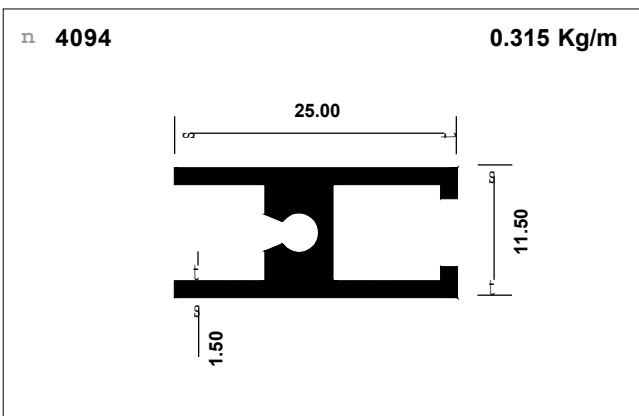
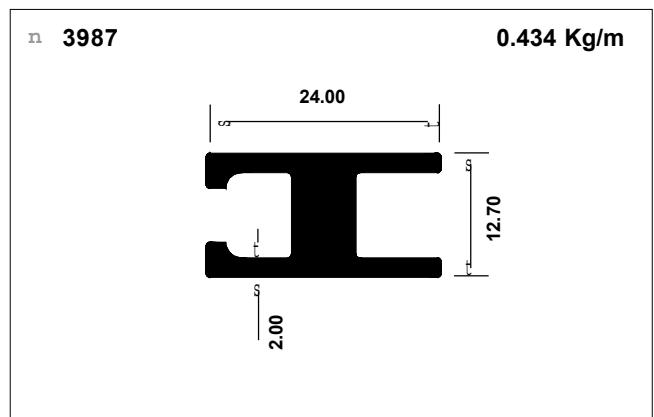
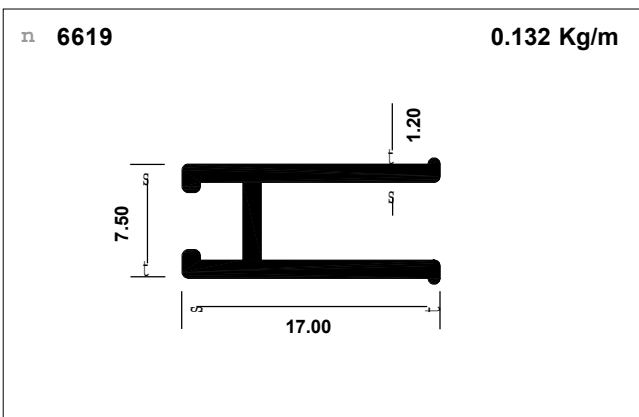
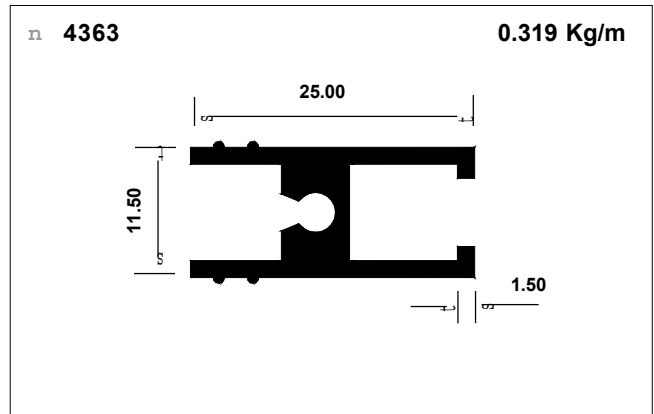
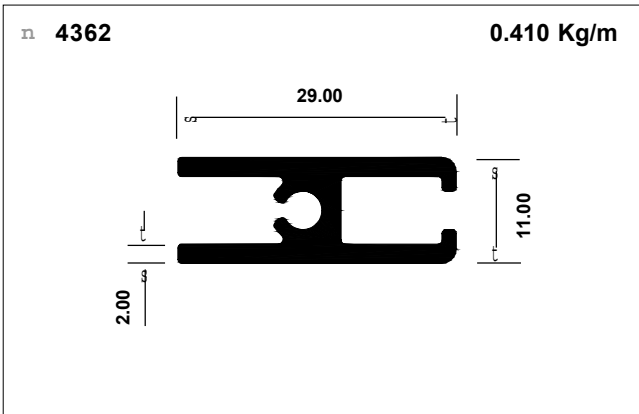

Bus windows

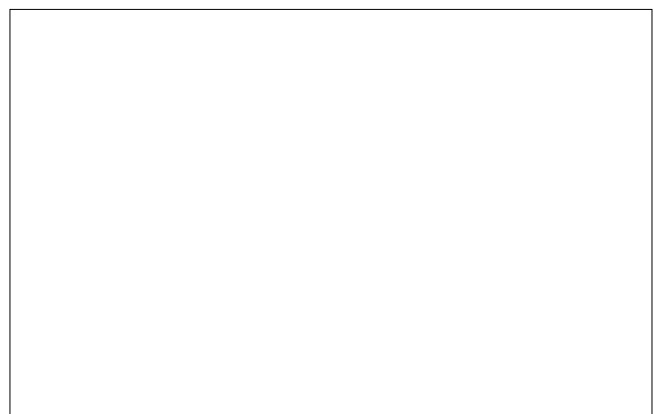
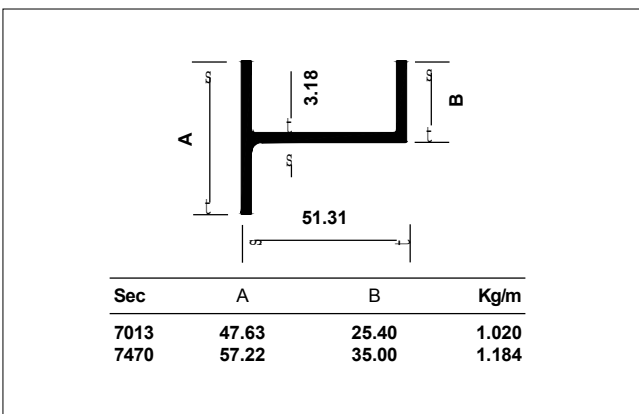
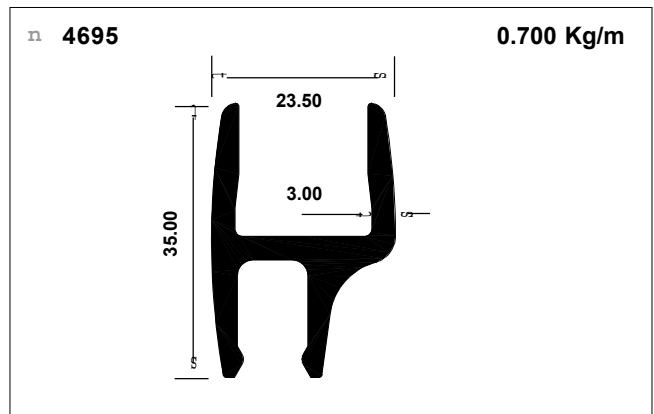
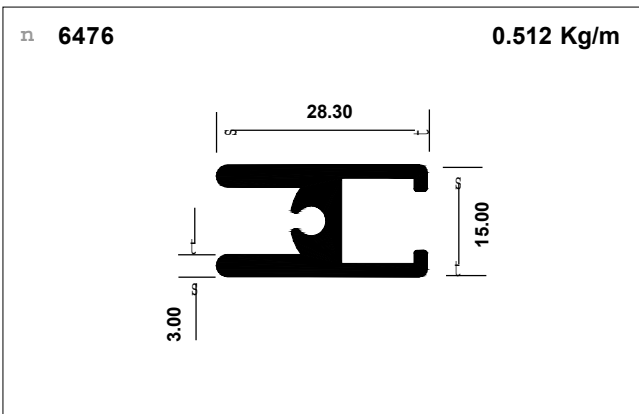
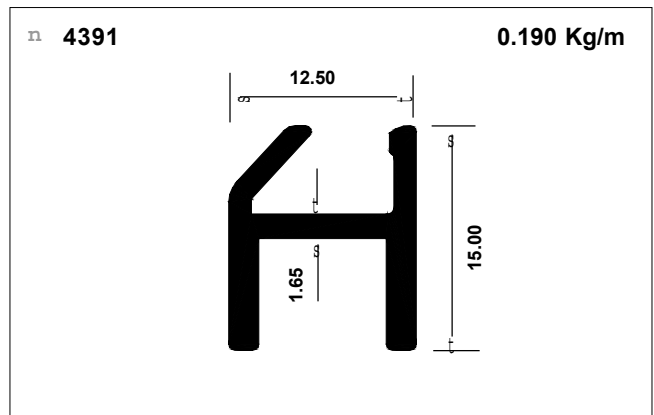
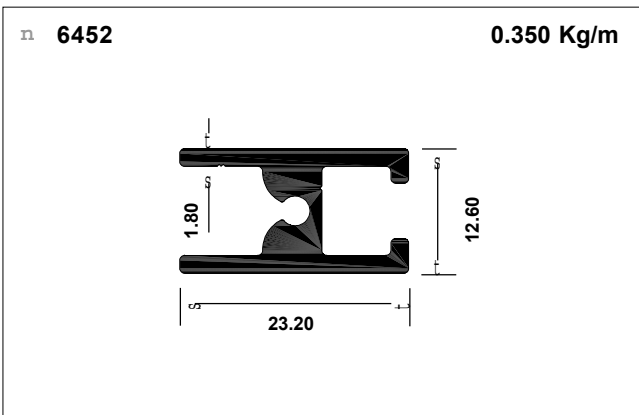
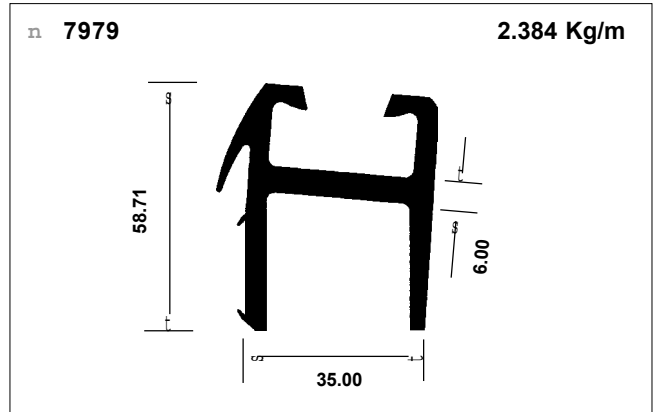
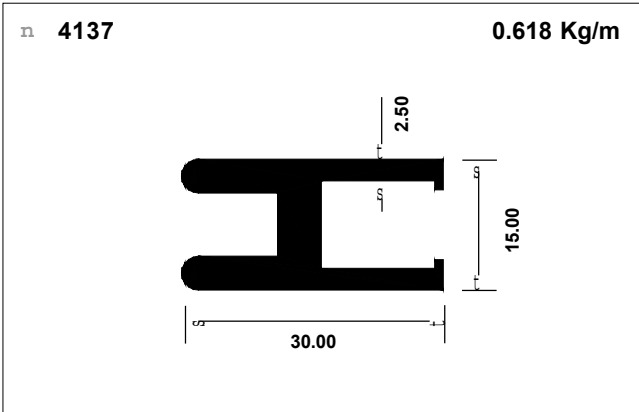

Bus windows

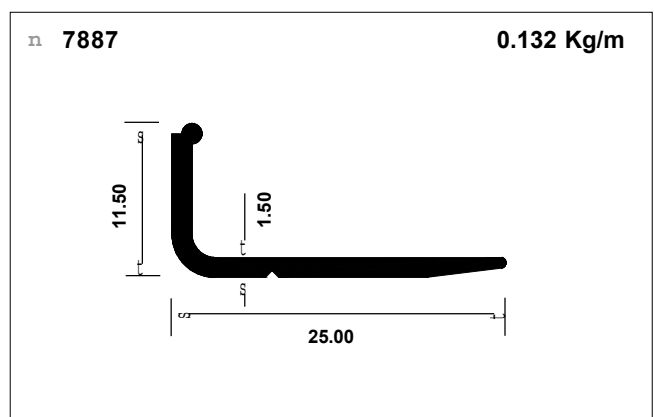
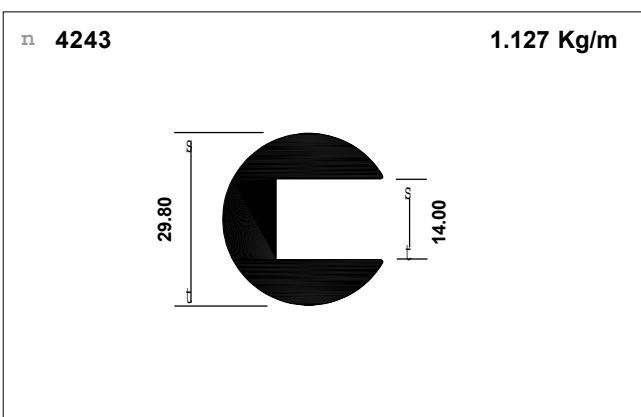
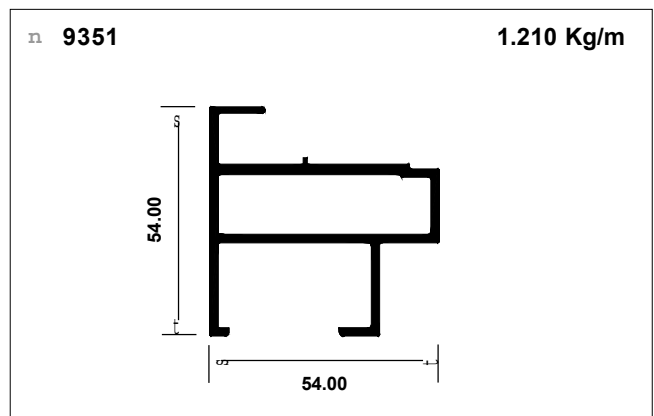
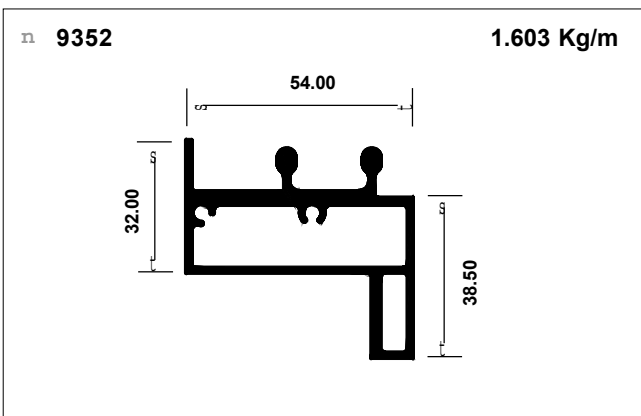
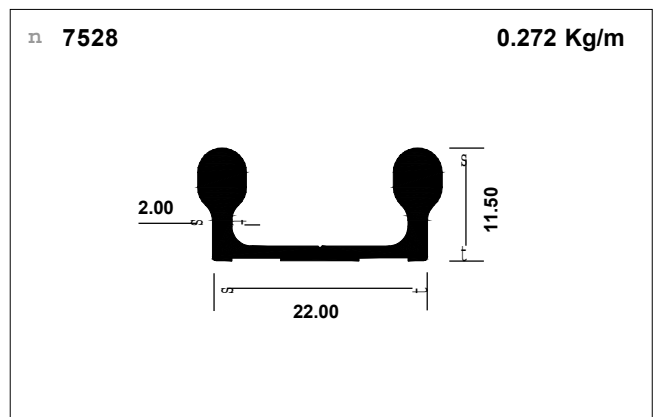
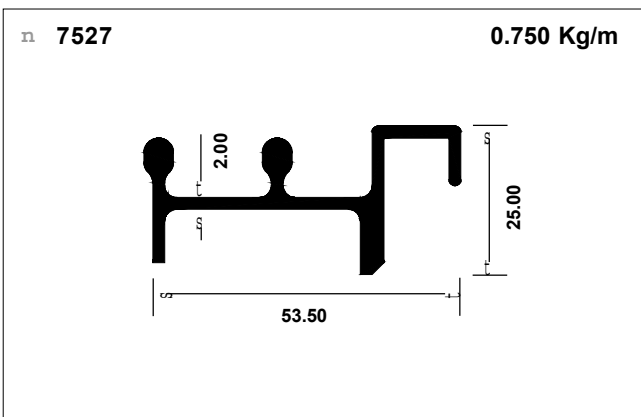
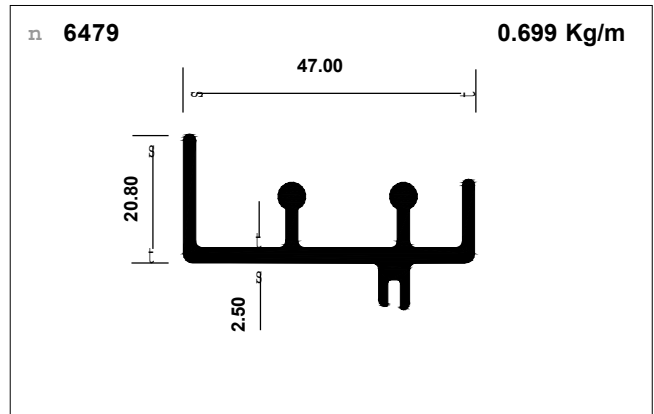
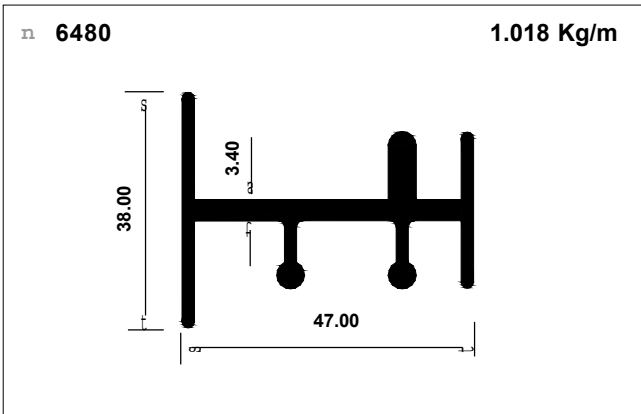

Bus windows

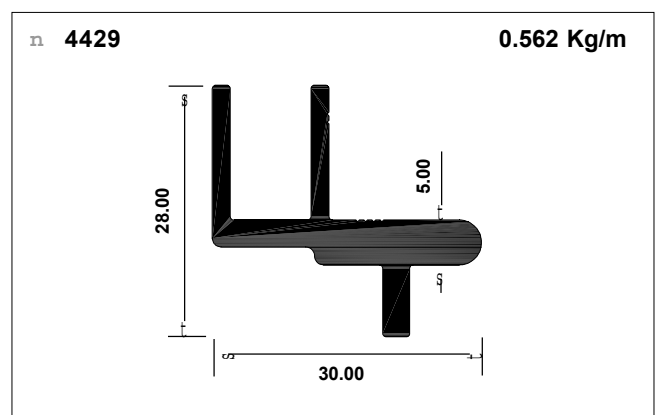
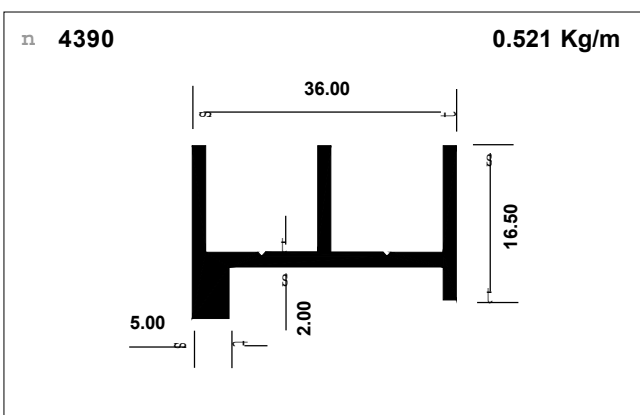
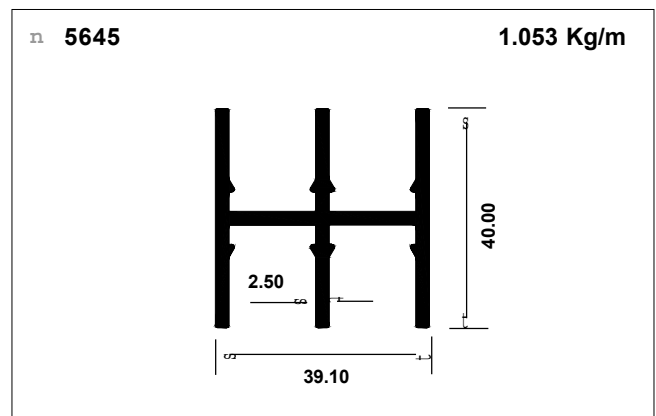
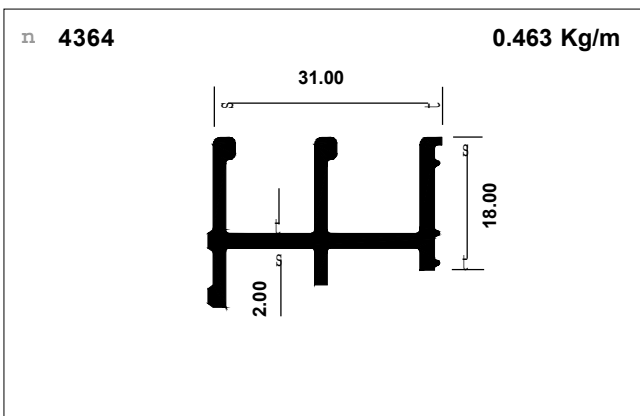
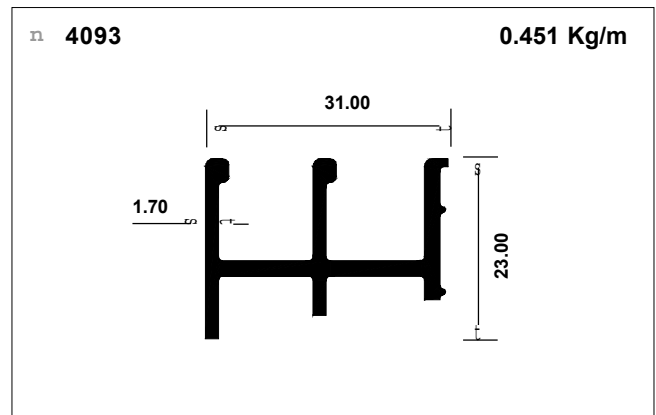
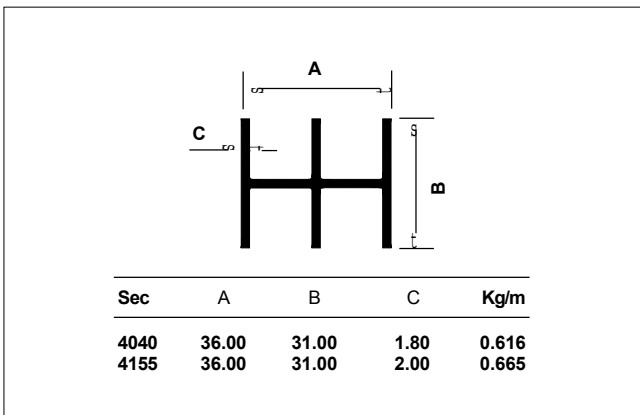
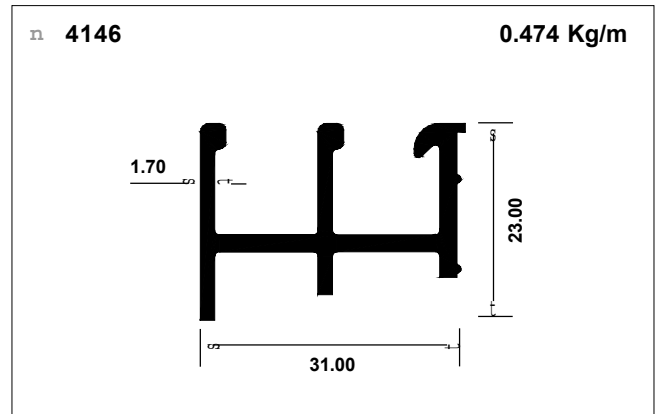
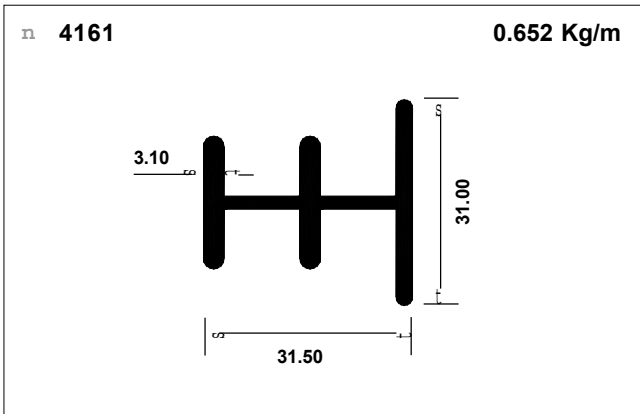

Bus windows

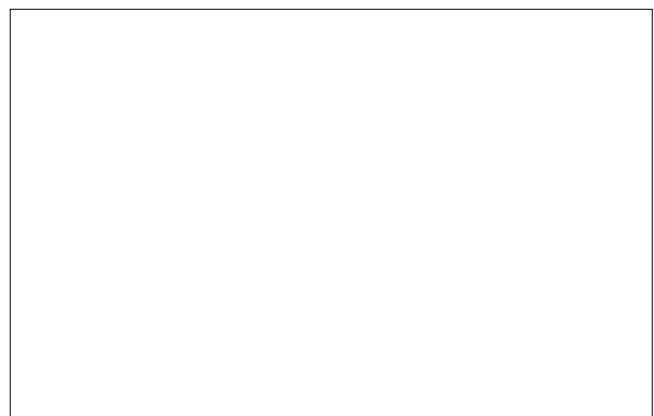
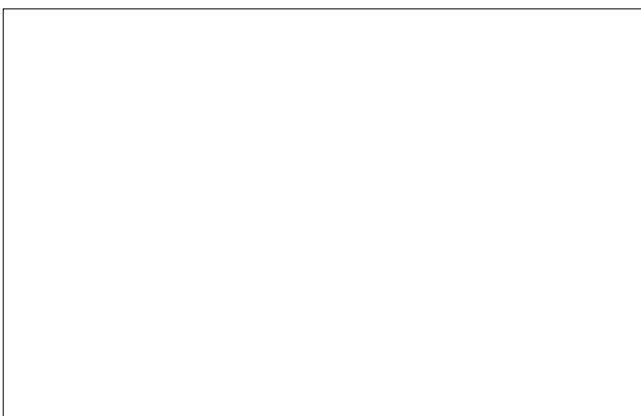
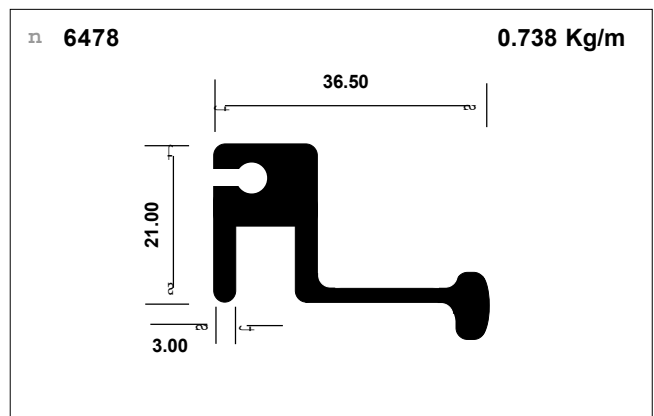
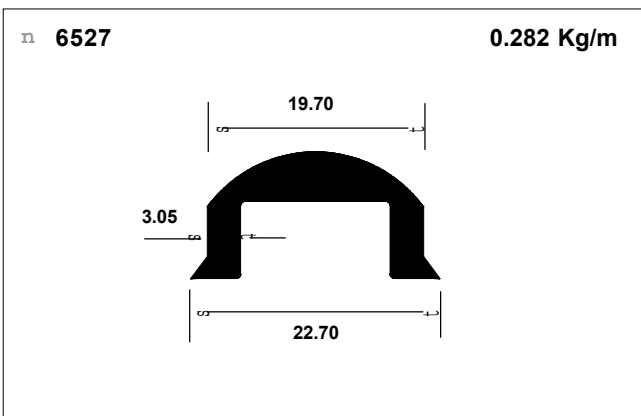
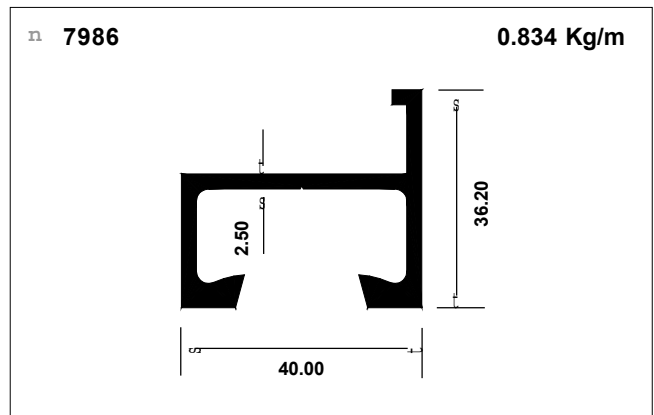
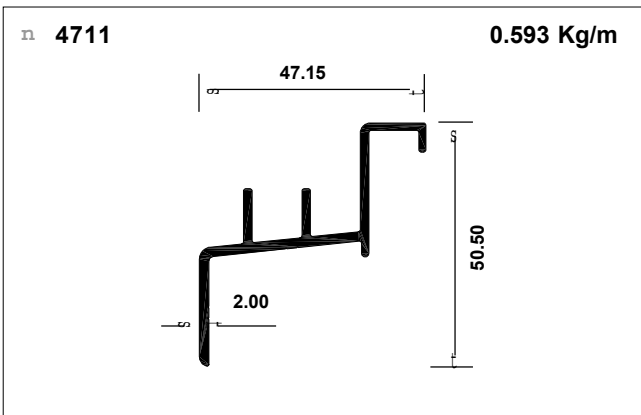
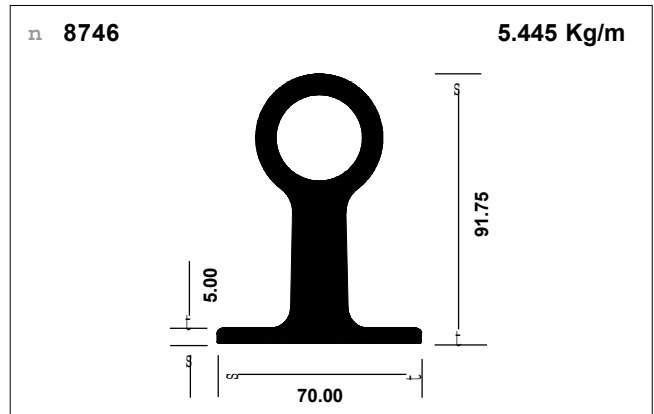
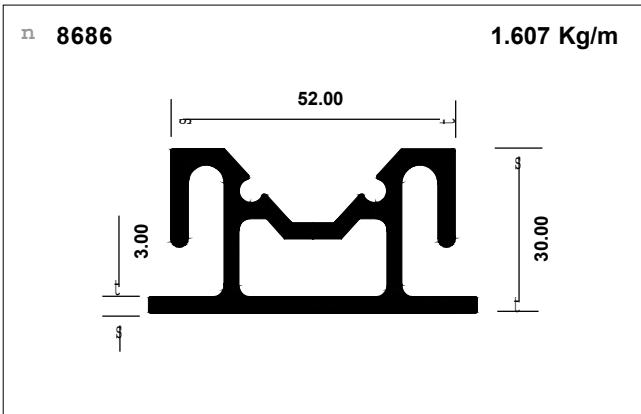

Bus windows

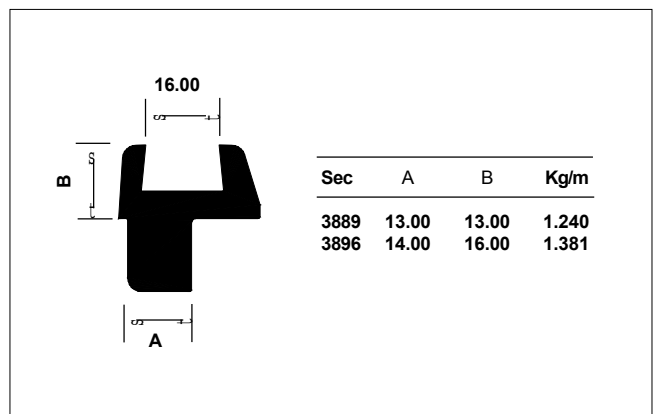
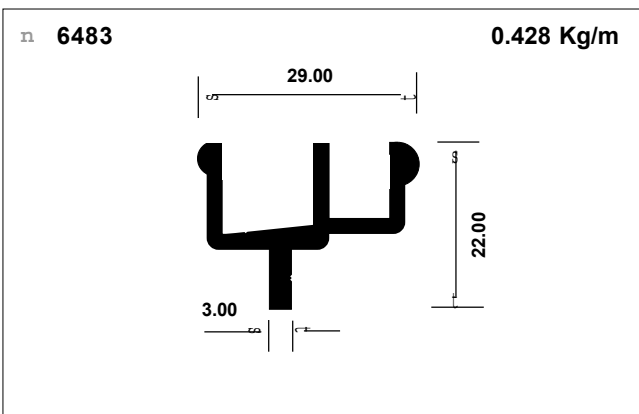
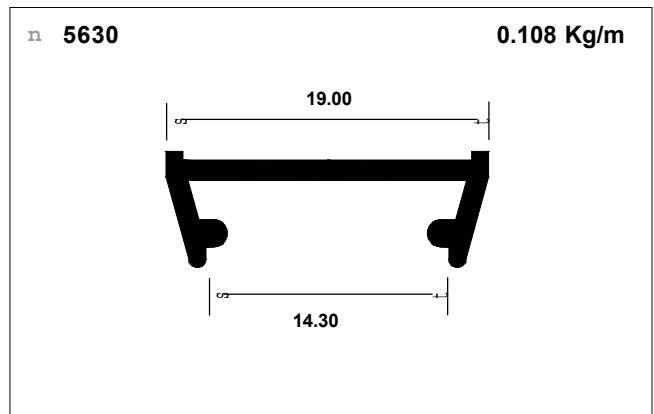
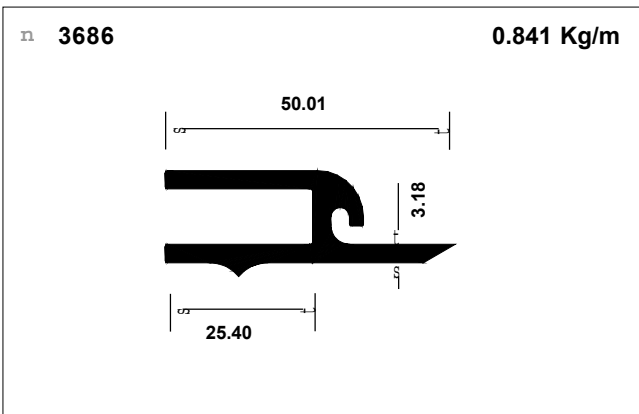
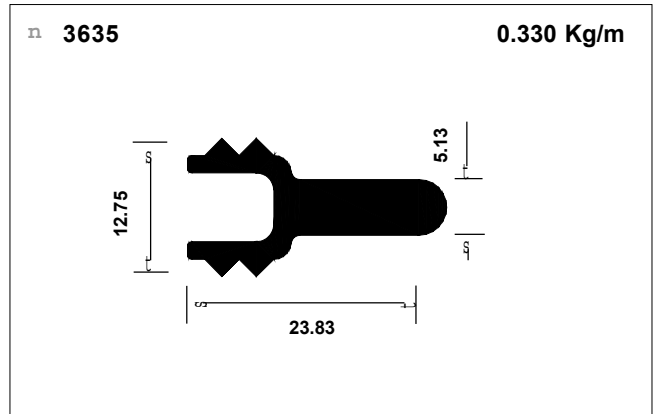
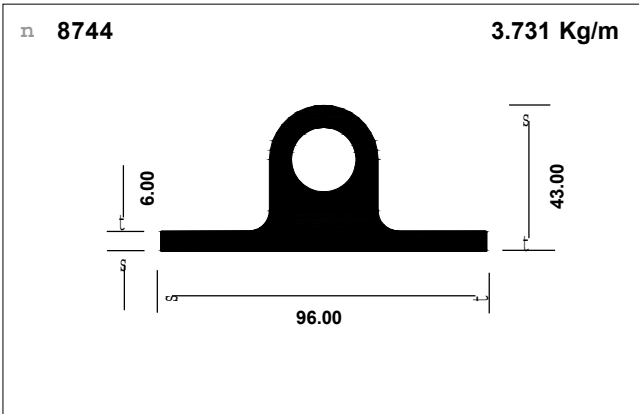
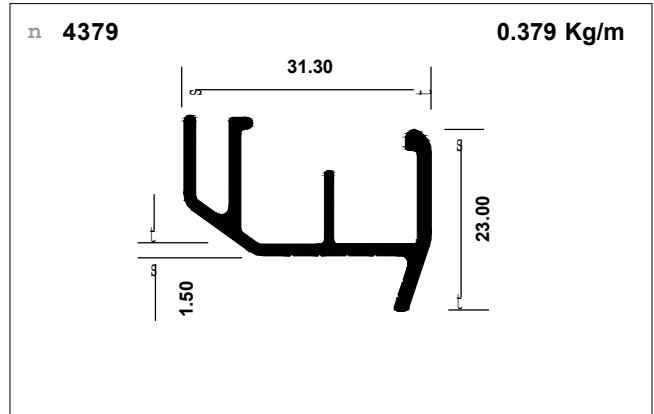
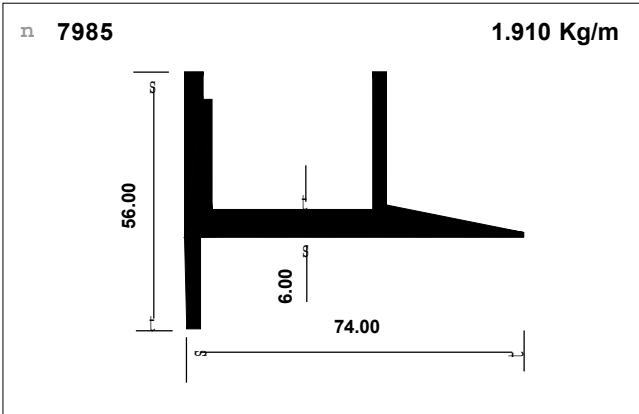

Bus windows

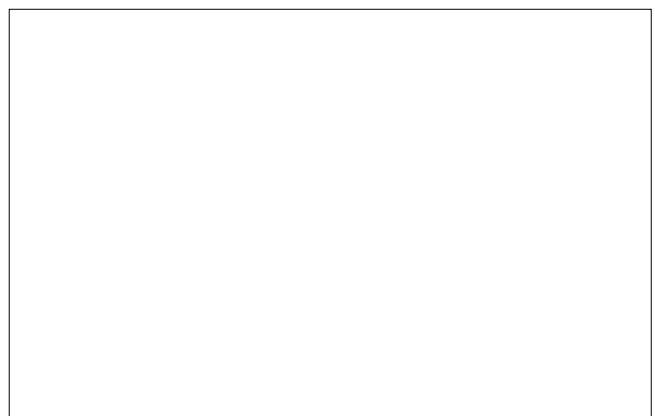
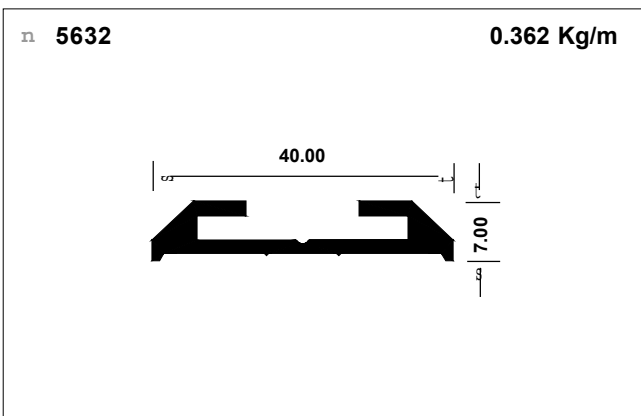
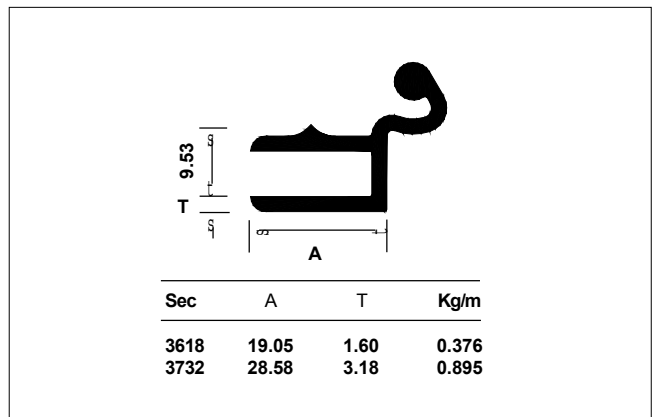
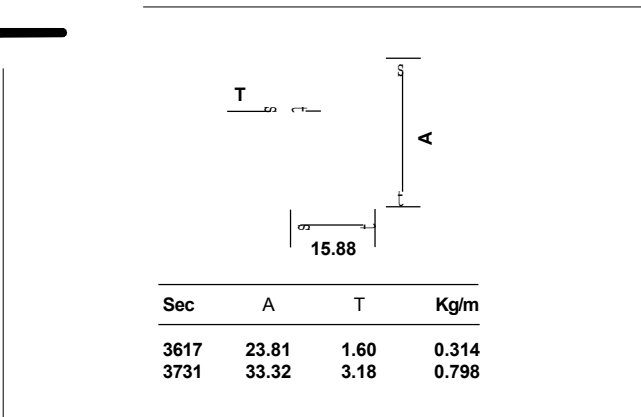
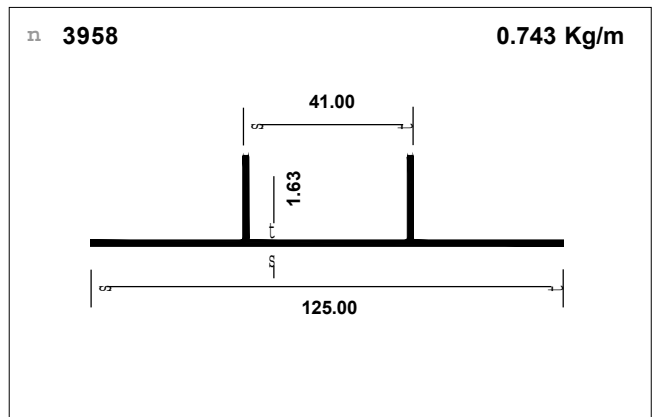
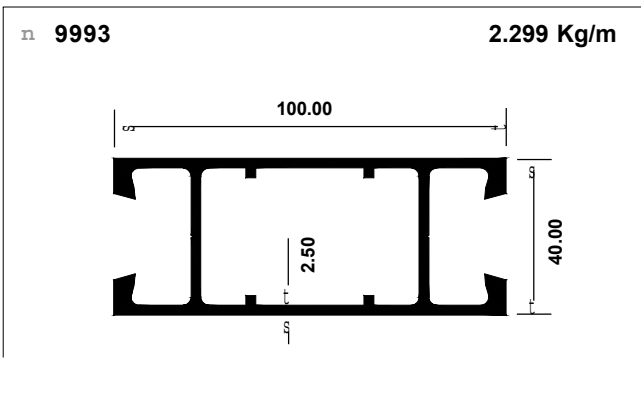
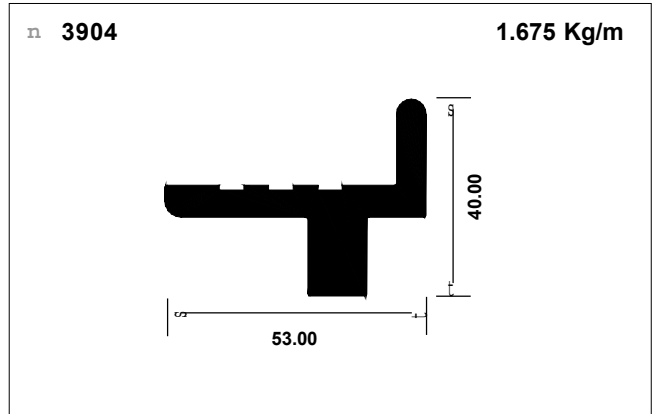
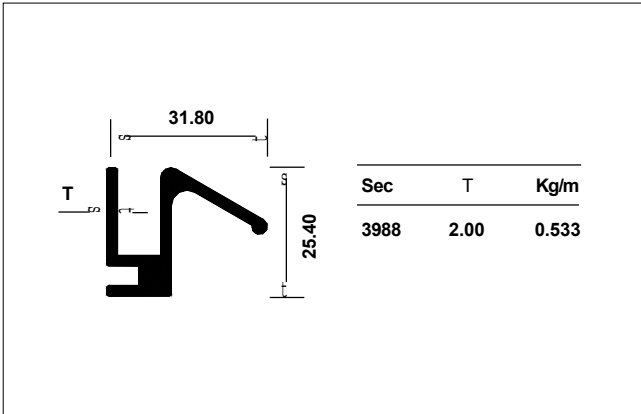

Bus windows

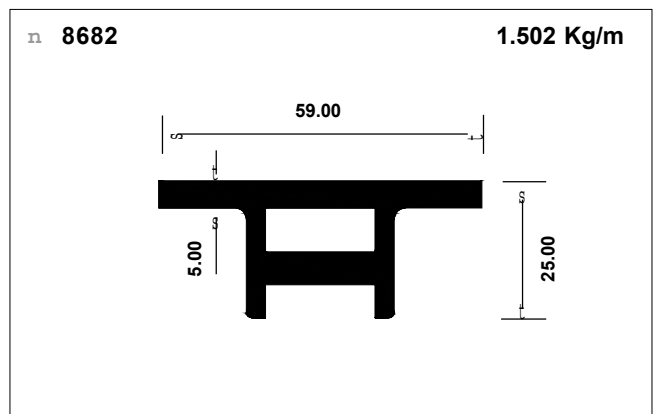
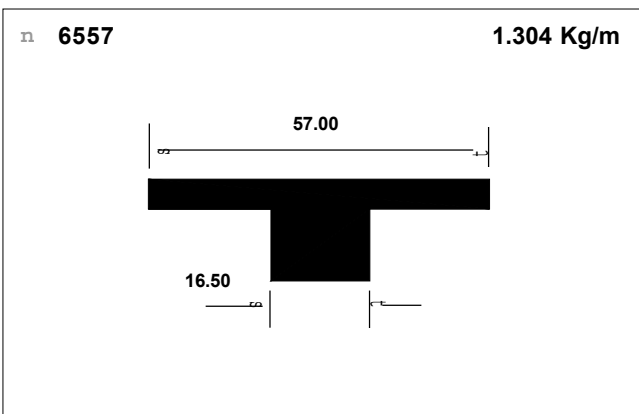
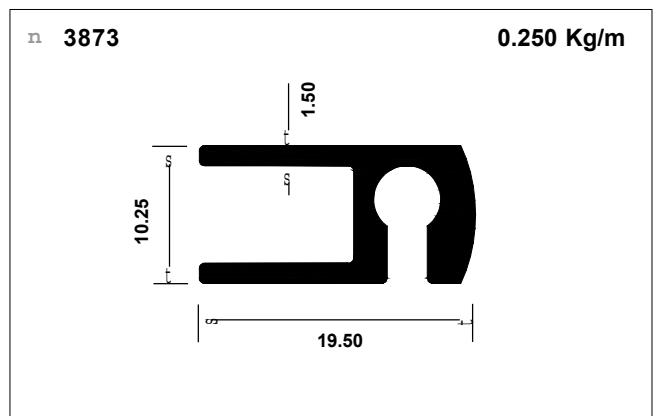
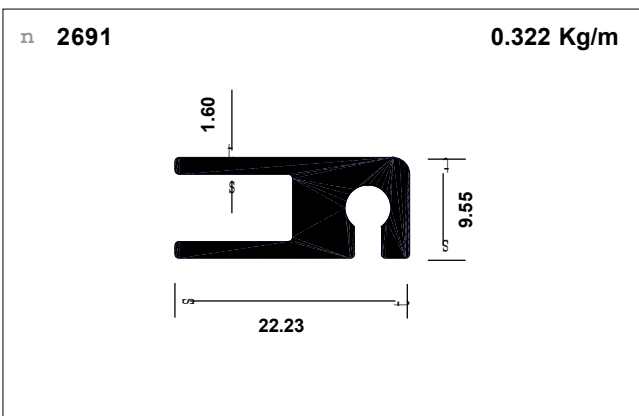
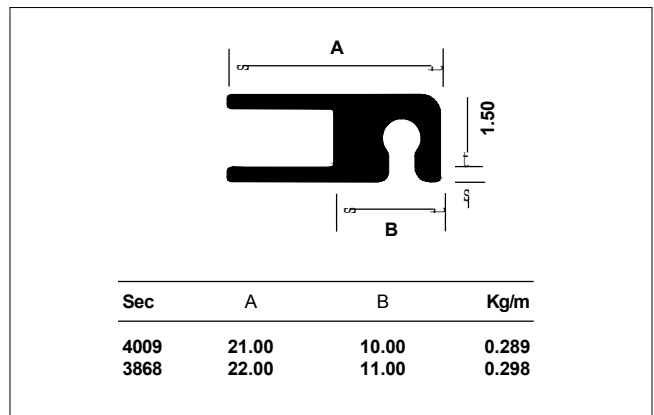
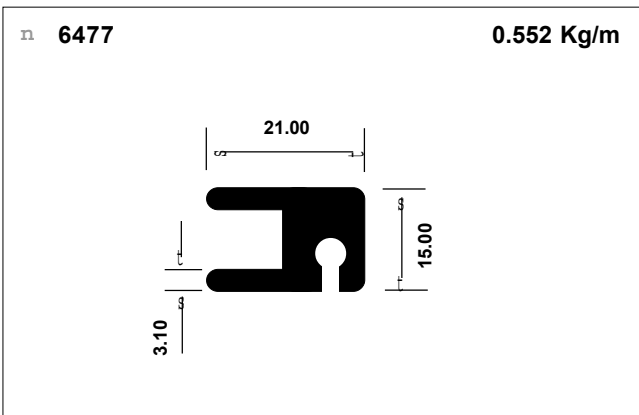
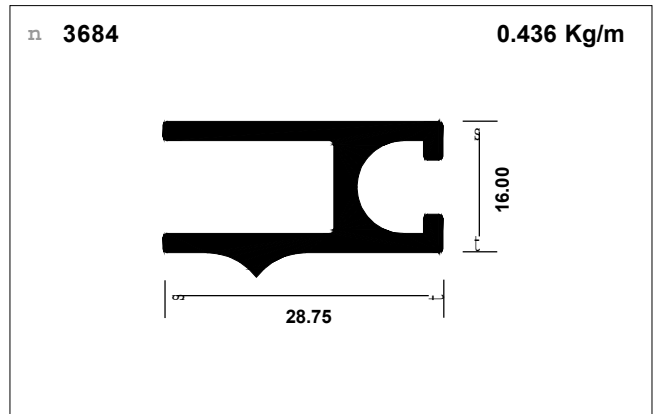
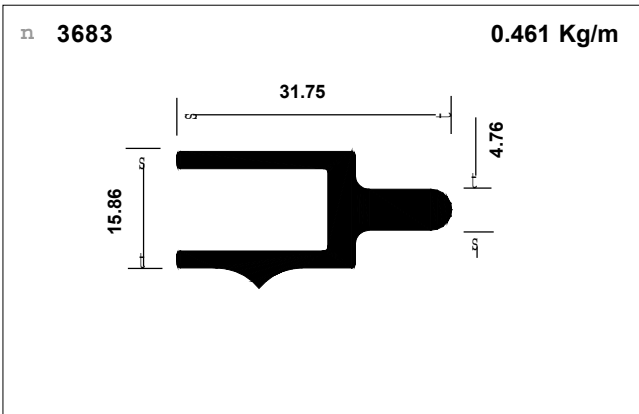

Bus structurals

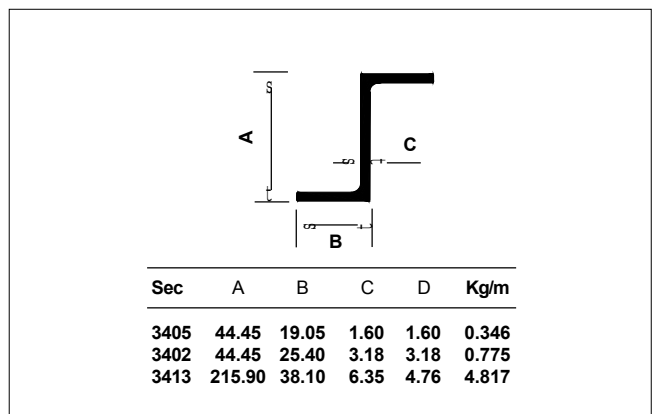
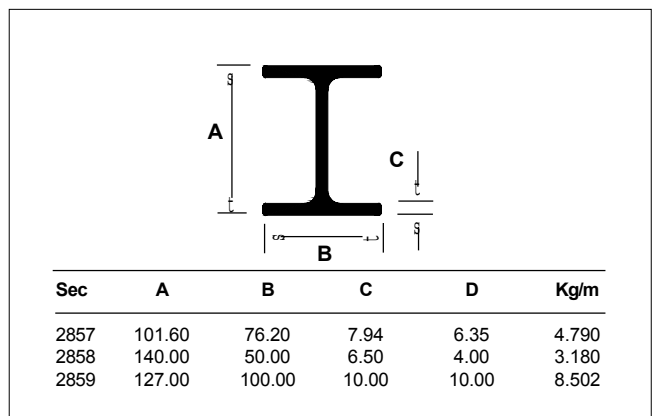
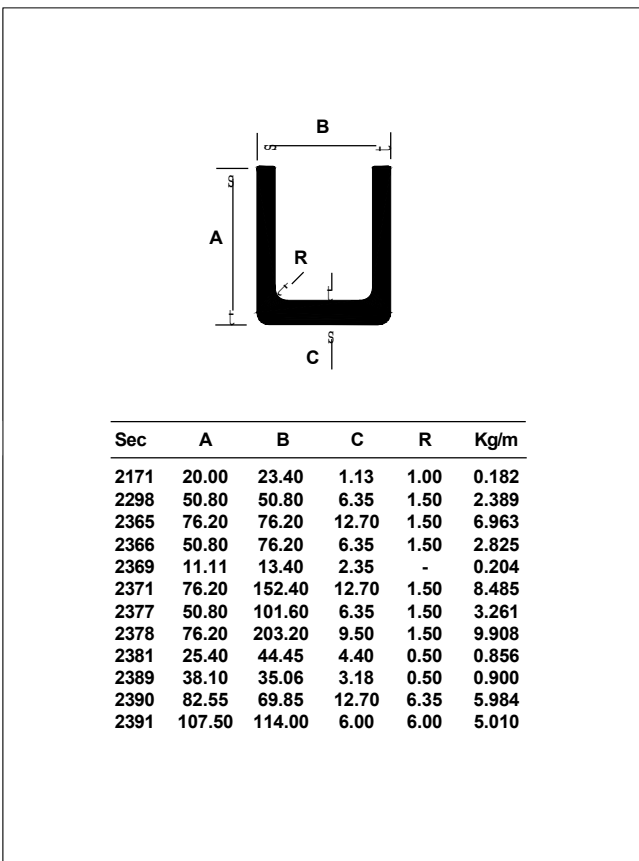
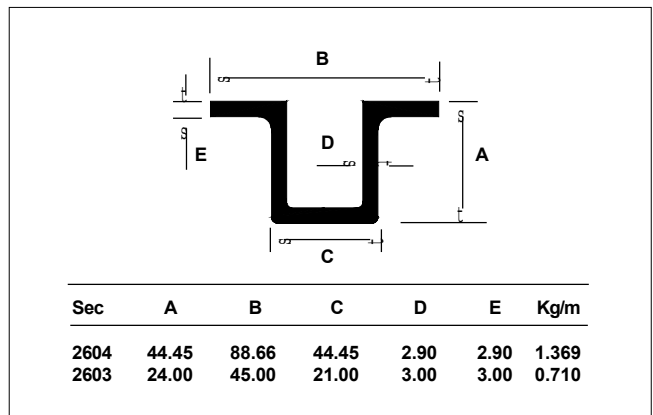
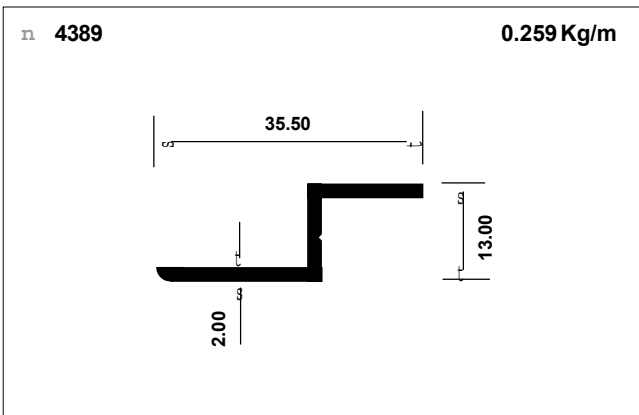
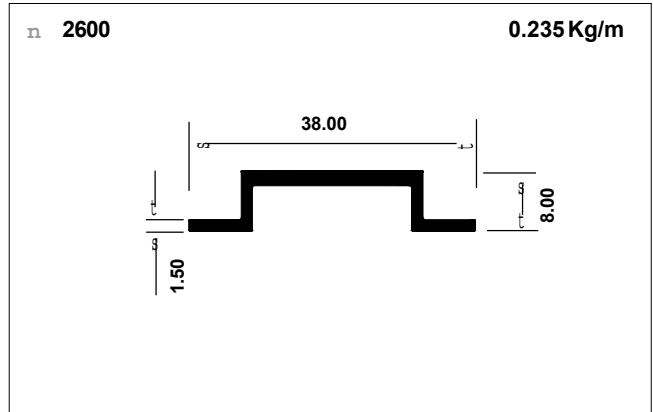
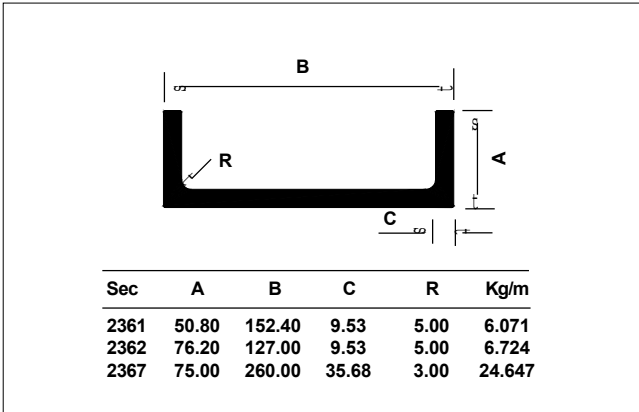

Bus structurals

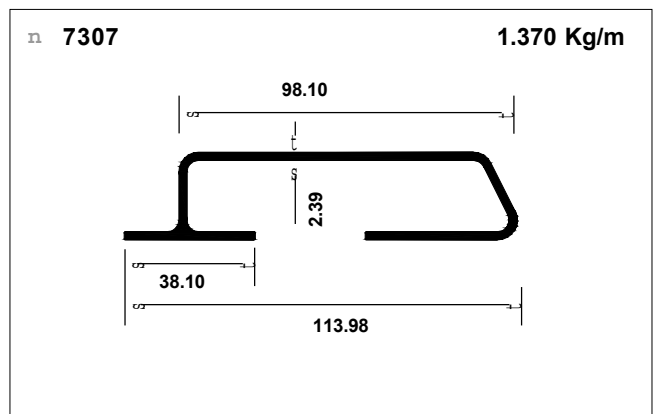
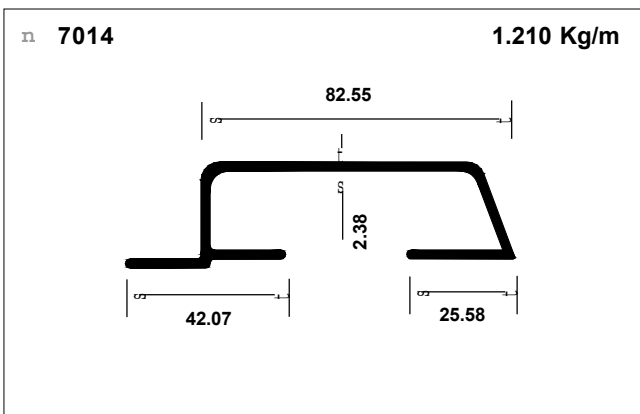
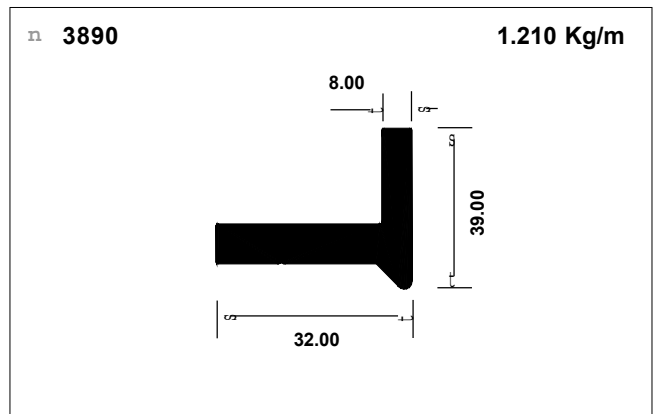
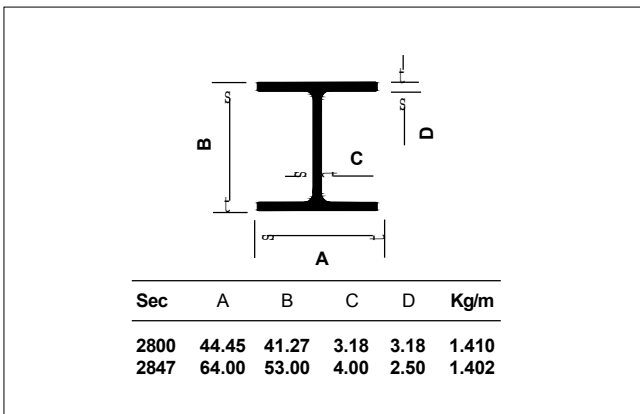
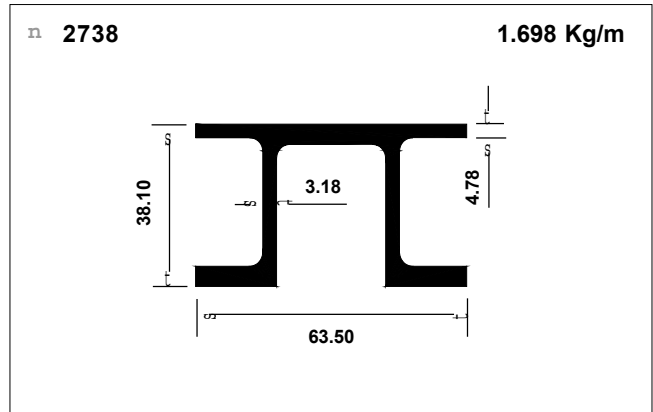
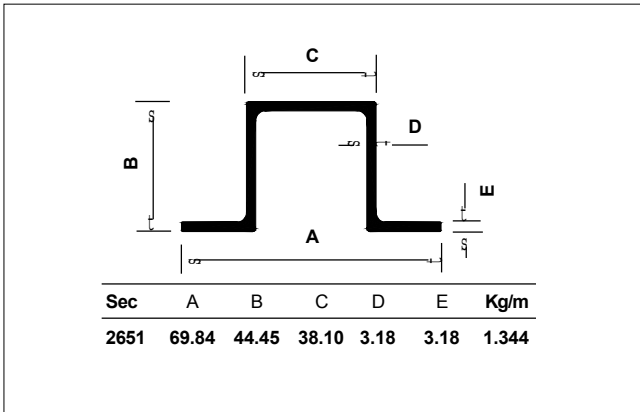
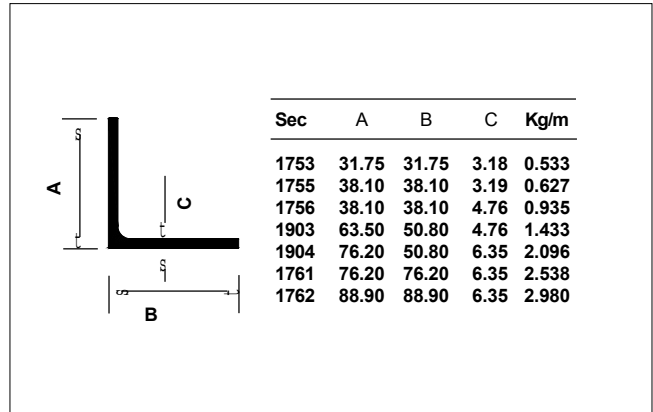
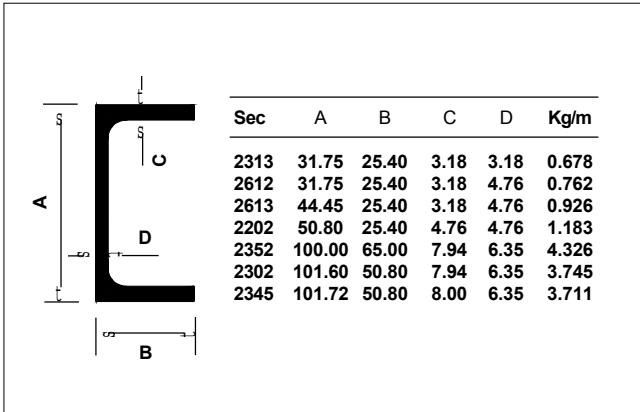

Bus structurals

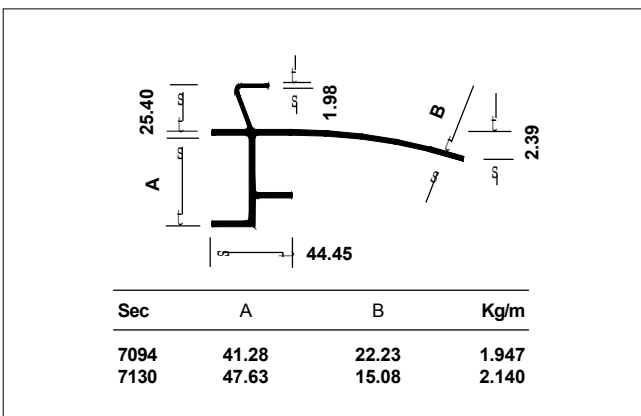
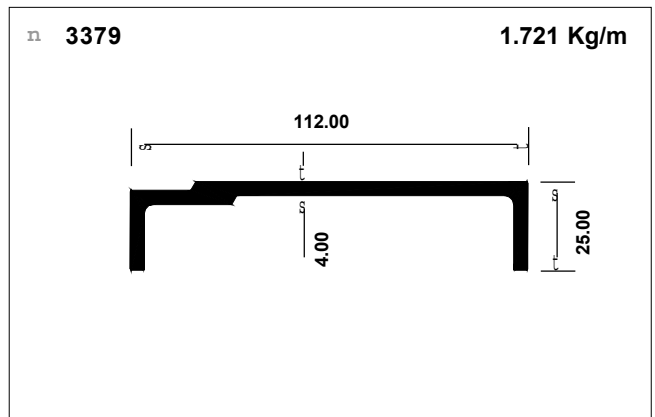
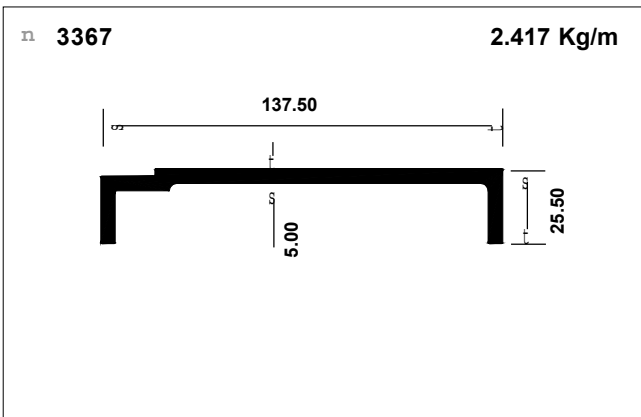
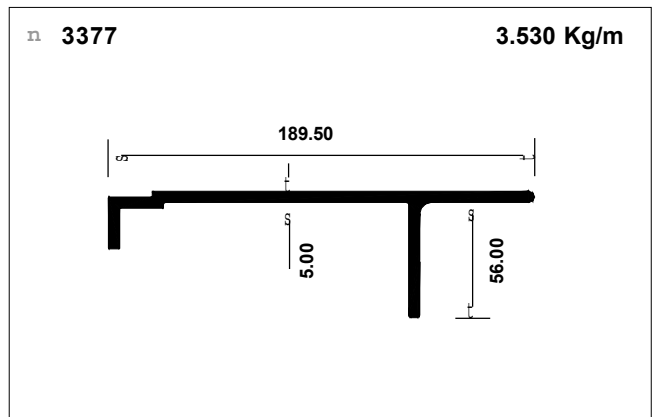
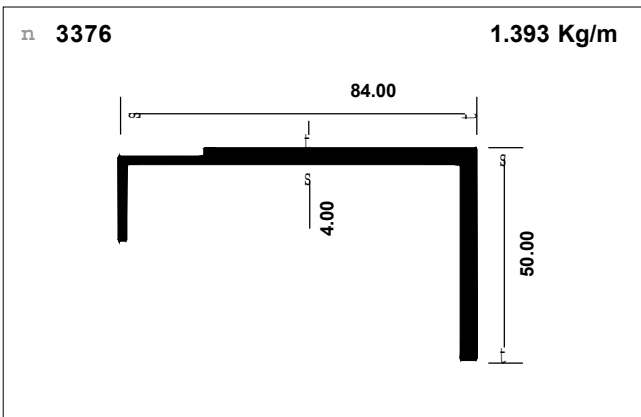
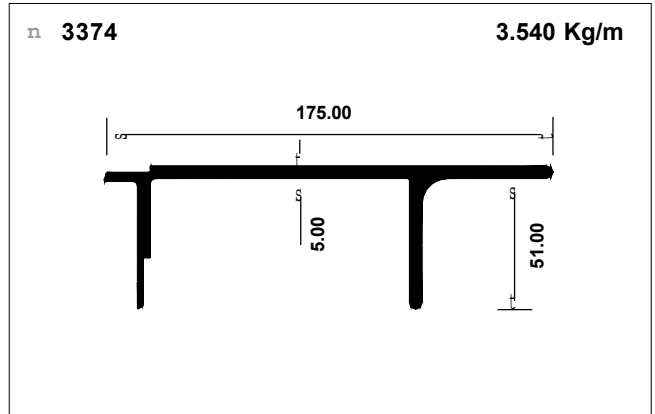
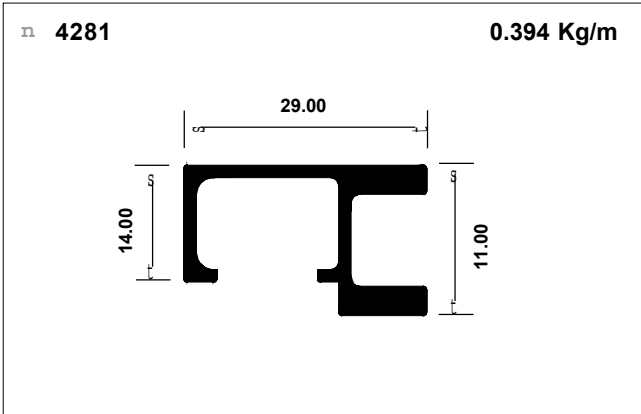

Bus structurals

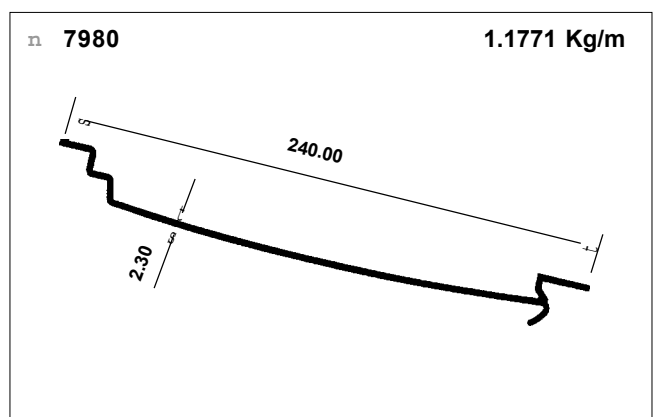
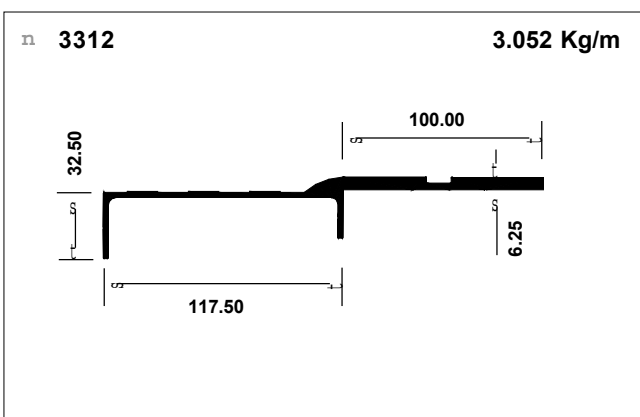
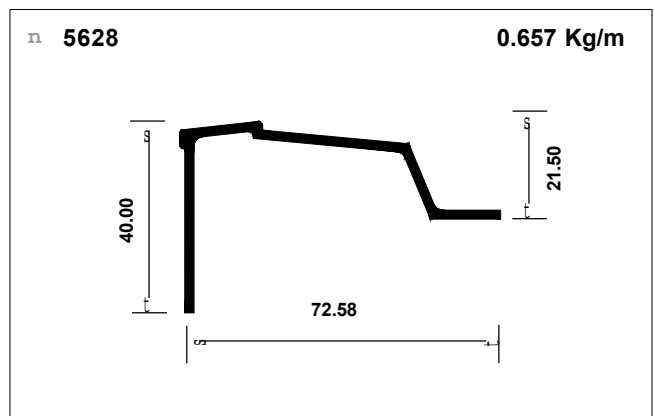
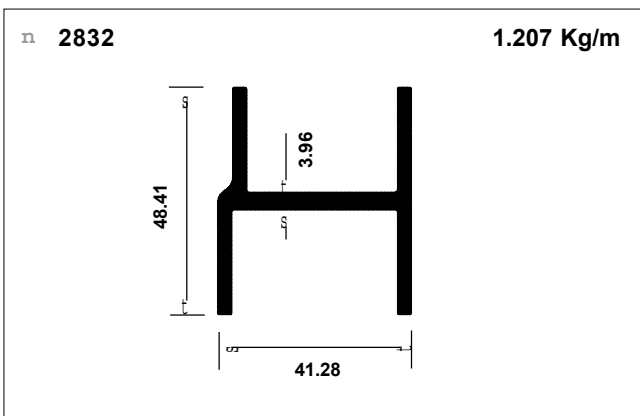
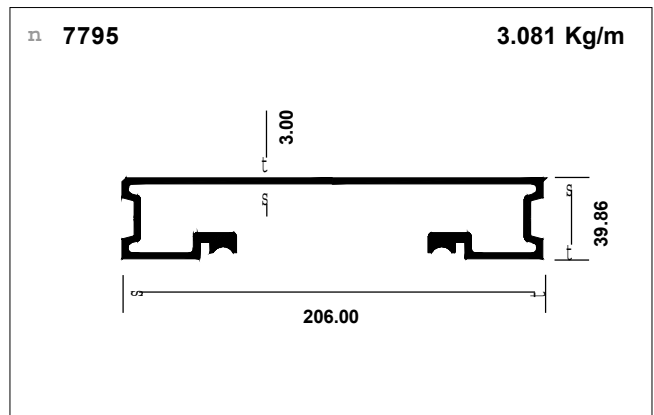
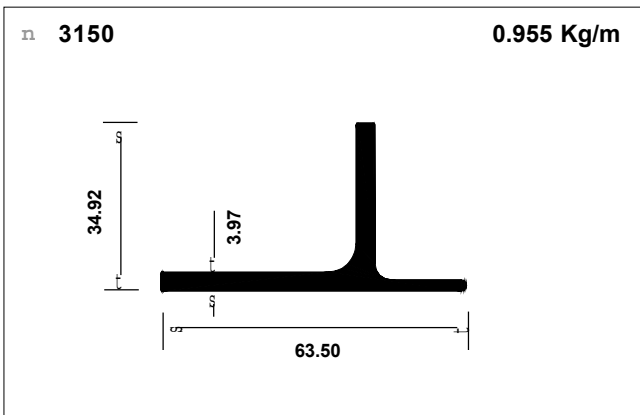
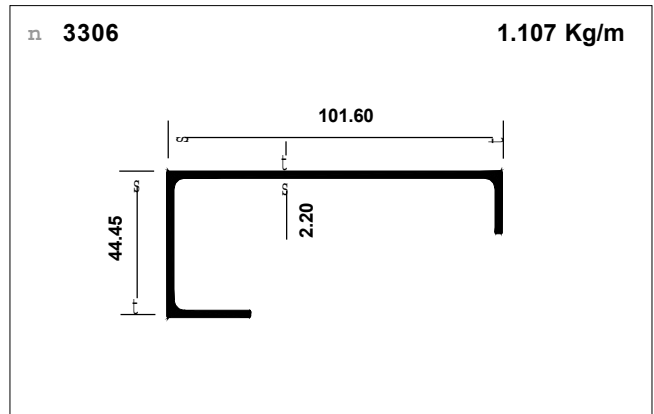
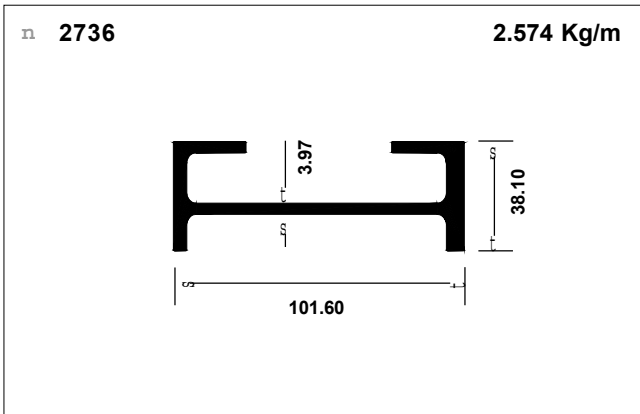

Bus structurals

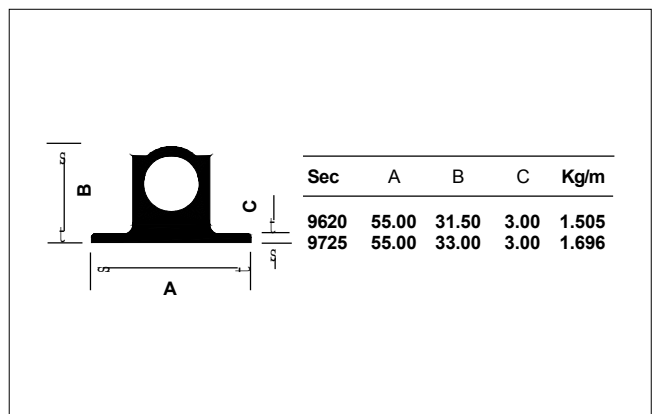
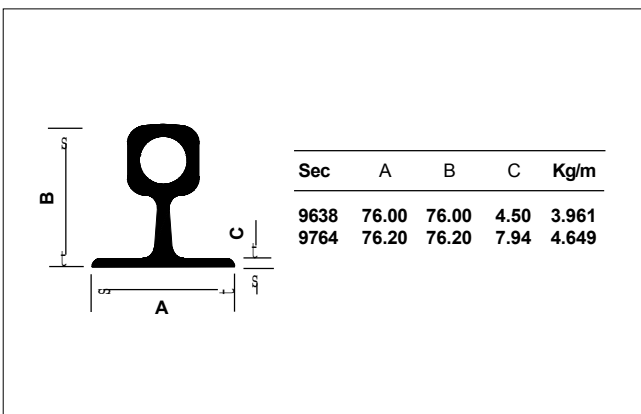
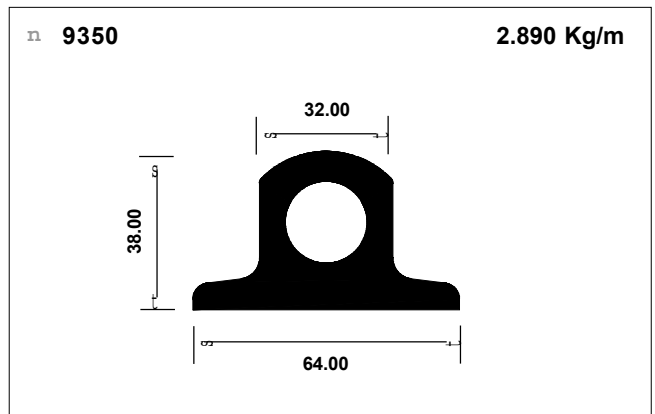
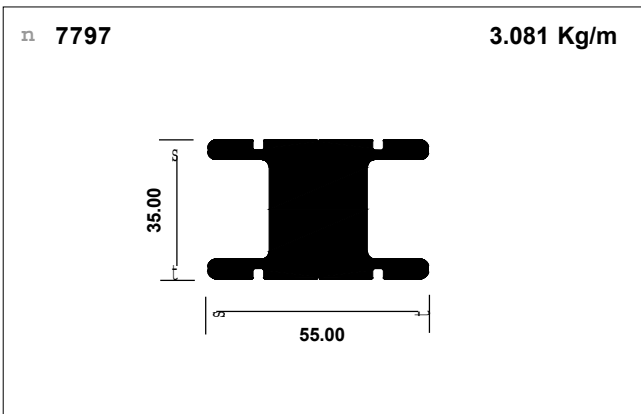
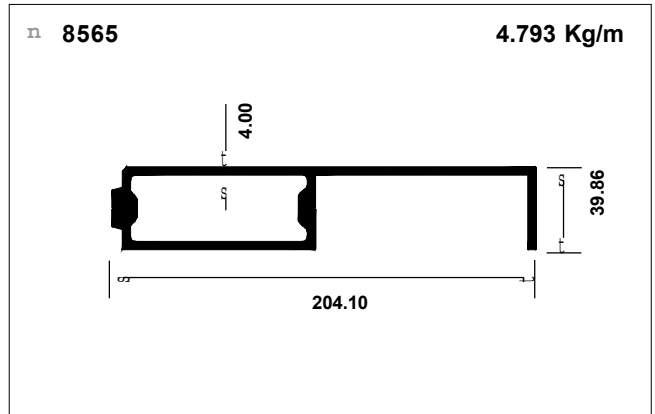
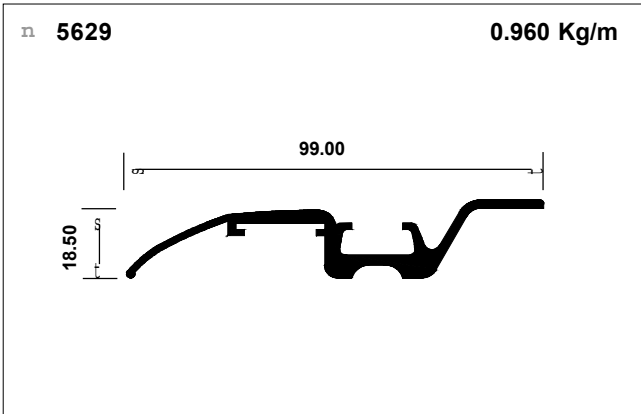
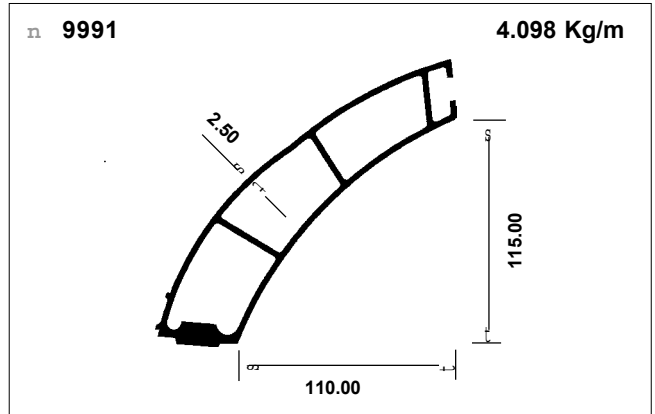
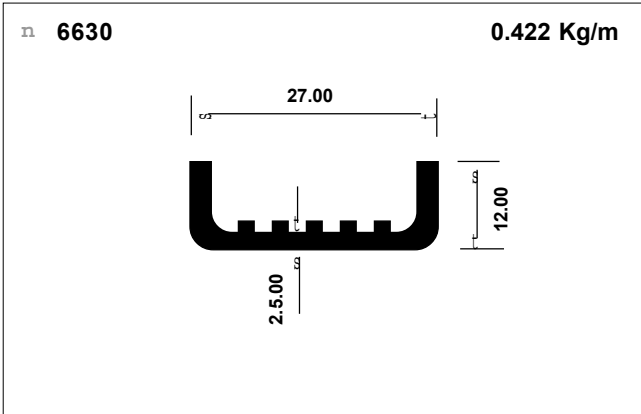

Flooring

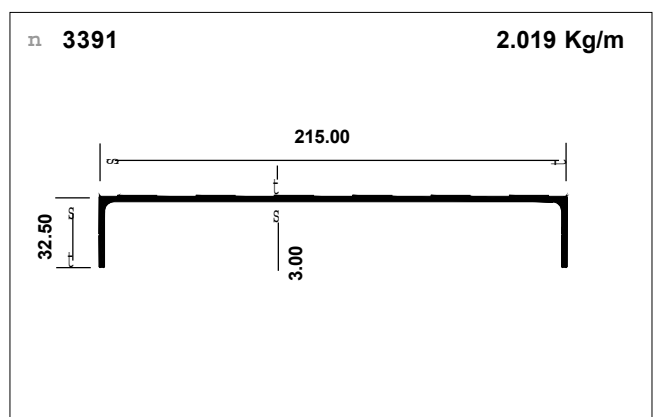
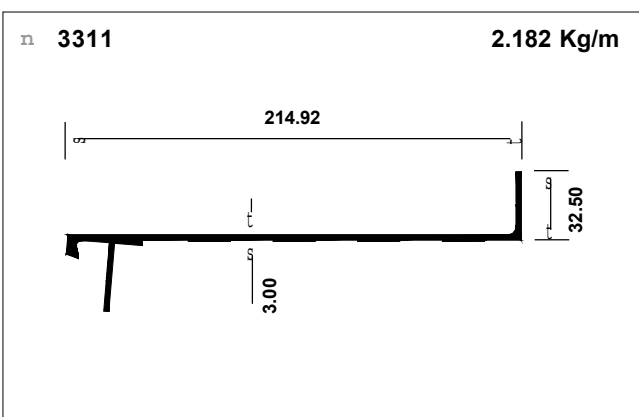
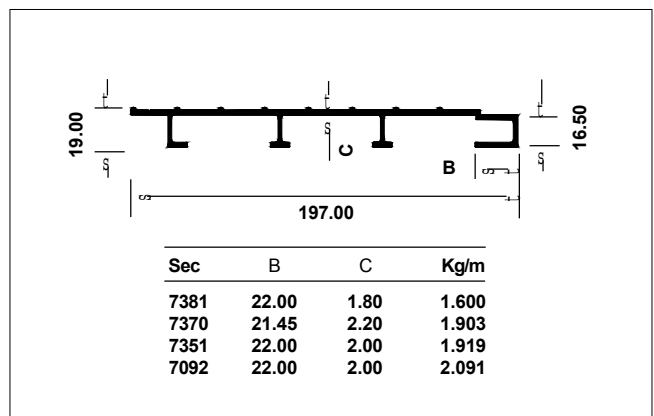
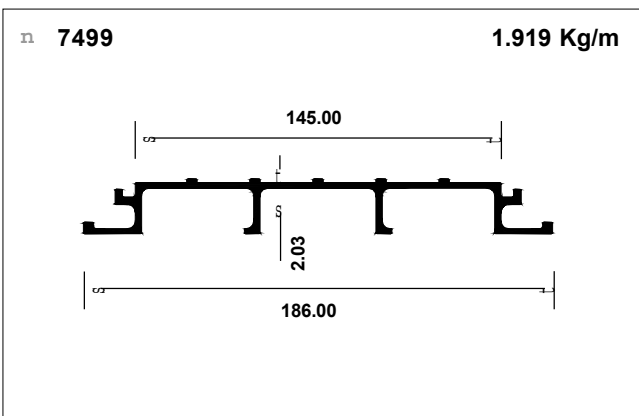
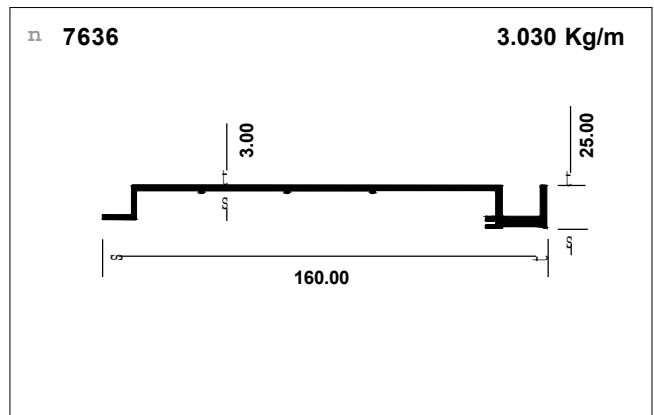
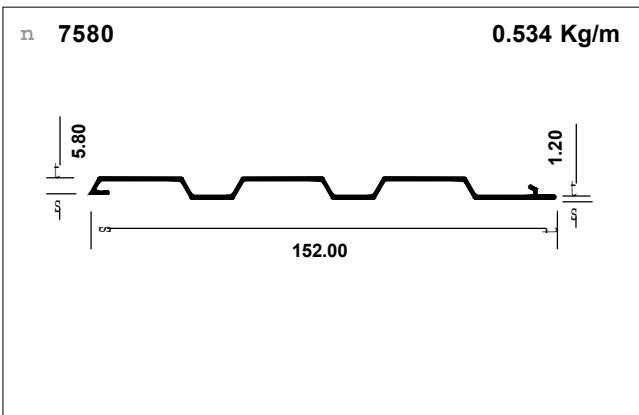
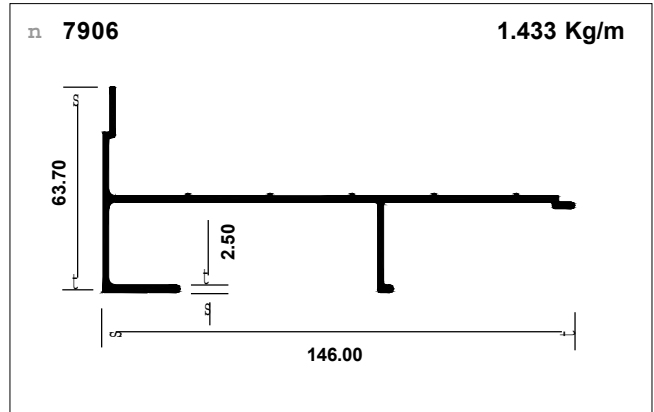
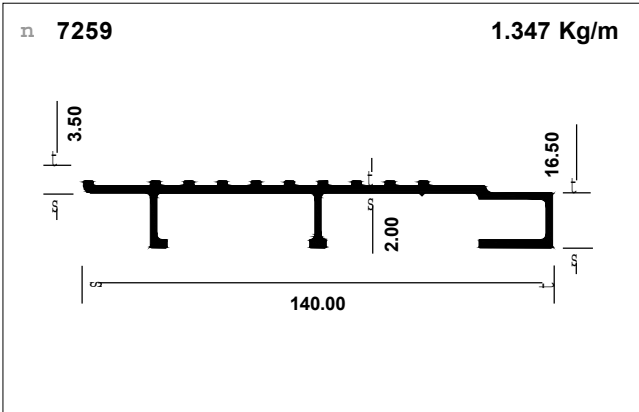

Flooring

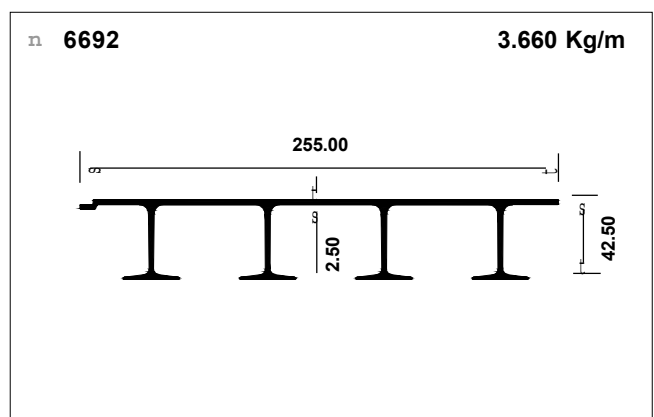
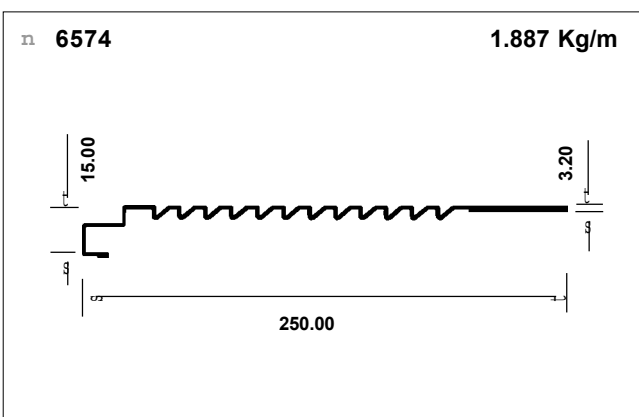
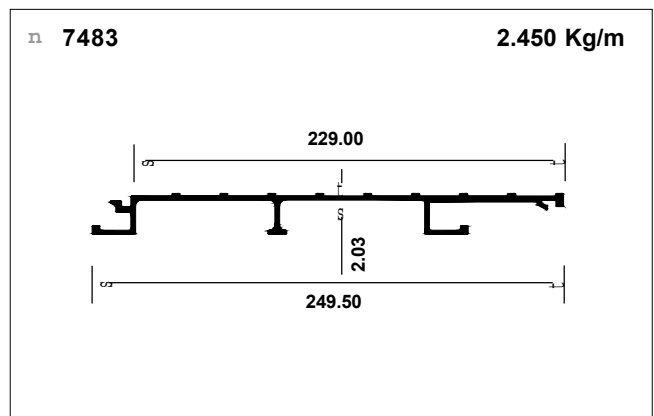
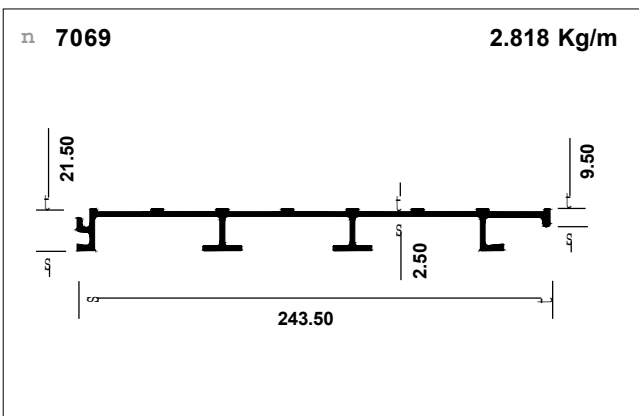
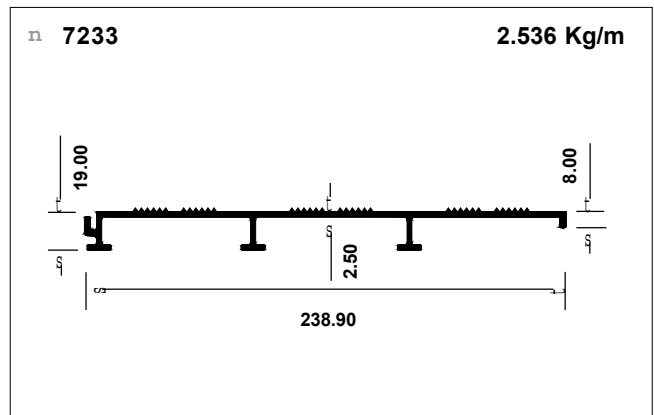
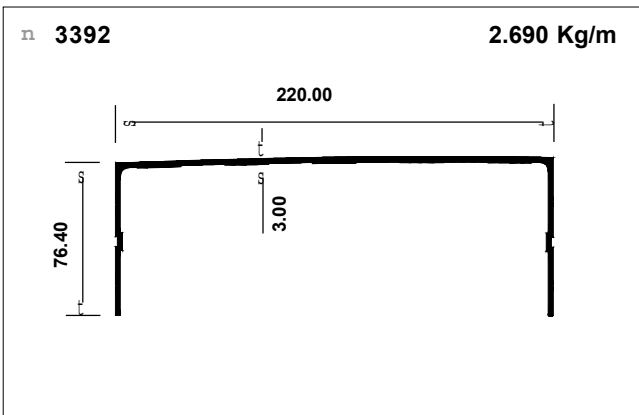
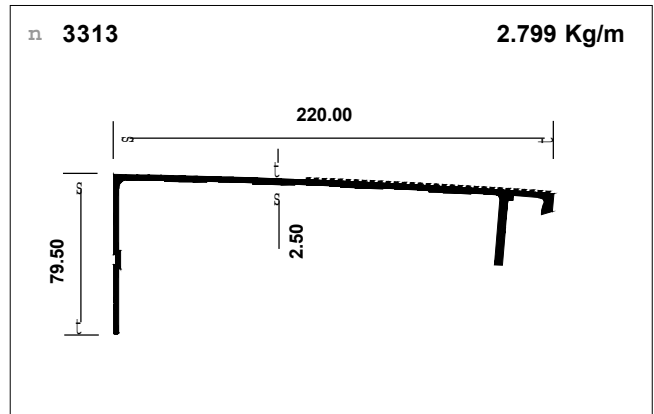
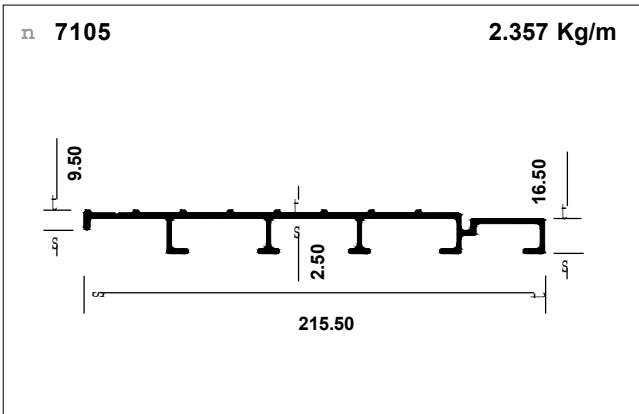



Flooring

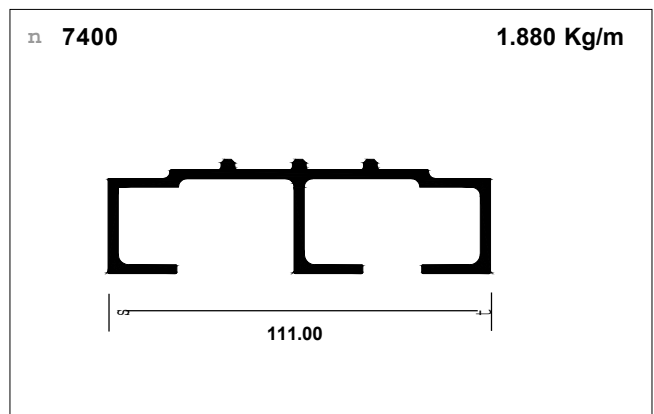
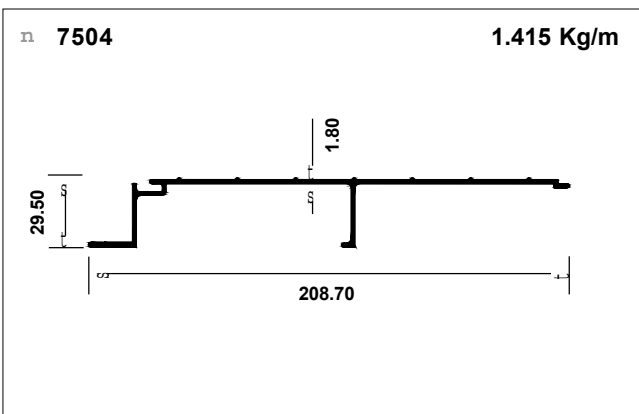
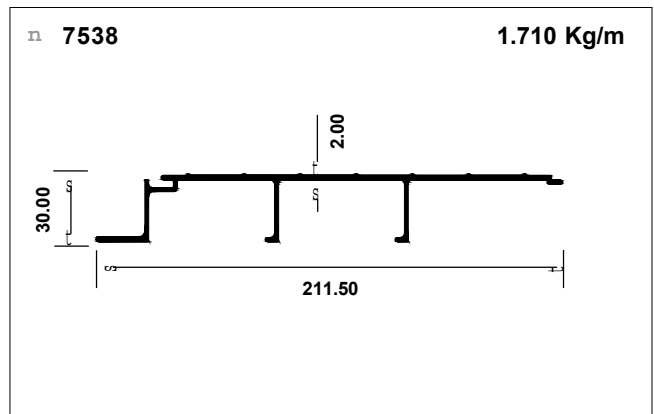
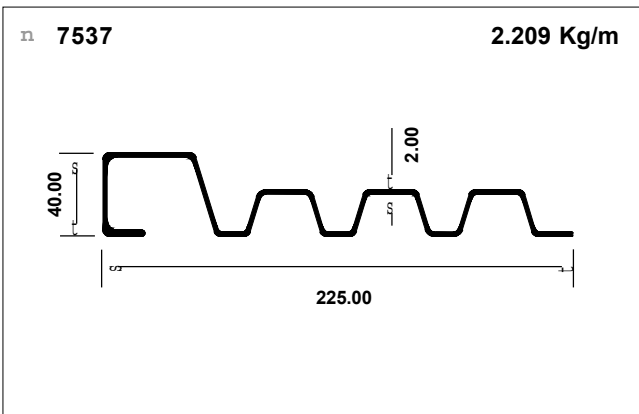
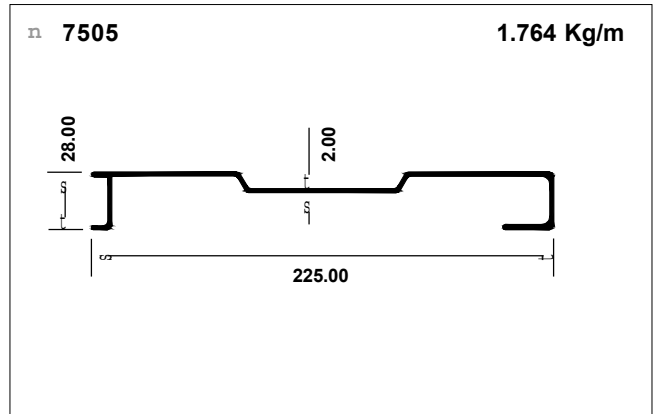
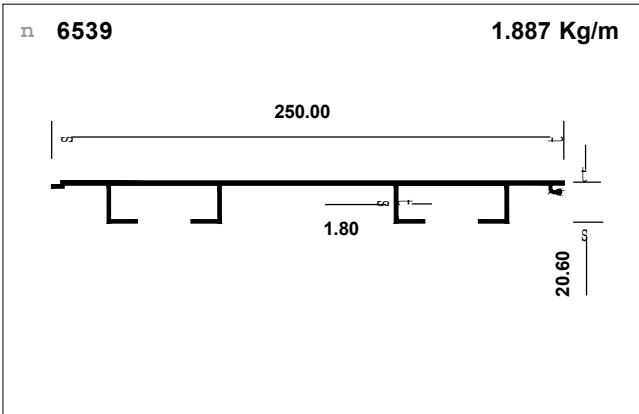
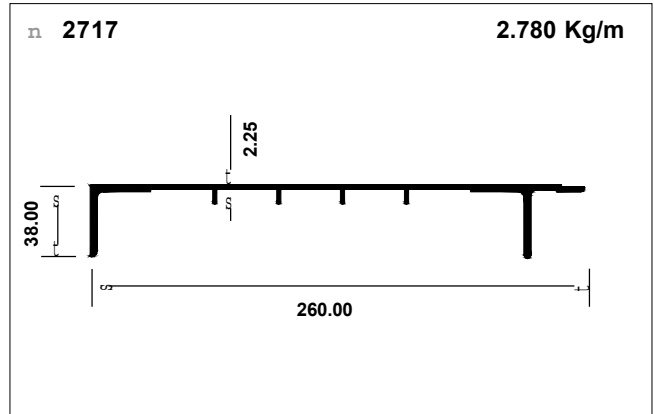
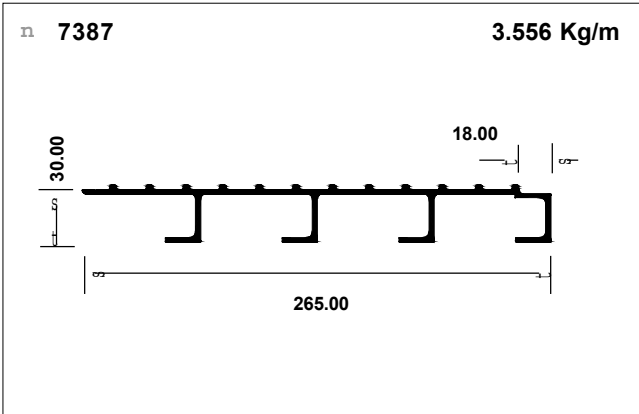

Bus body miscellaneous

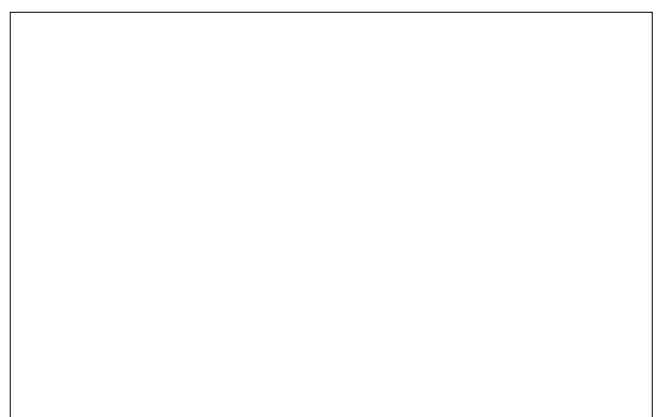
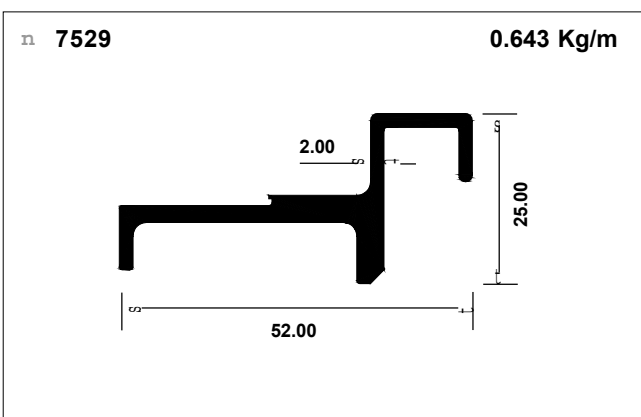
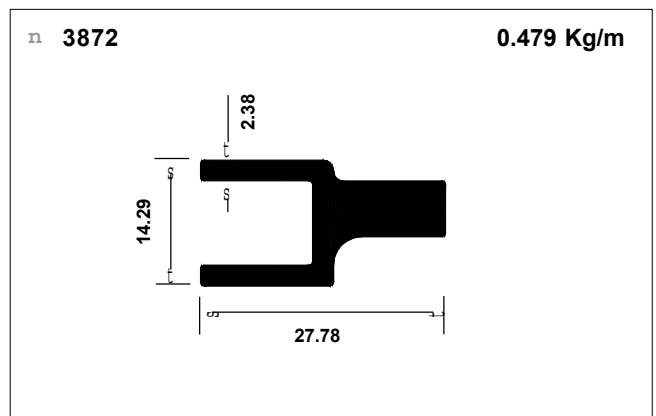
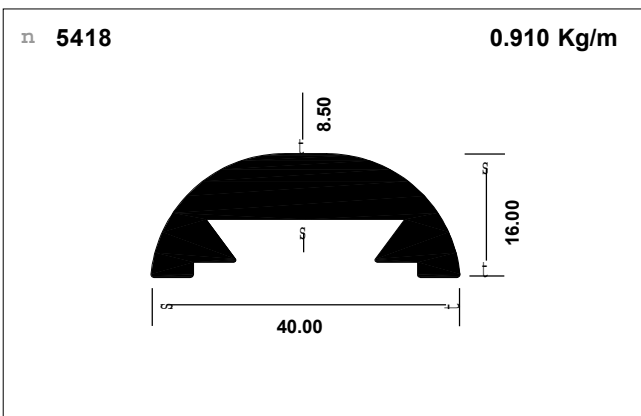
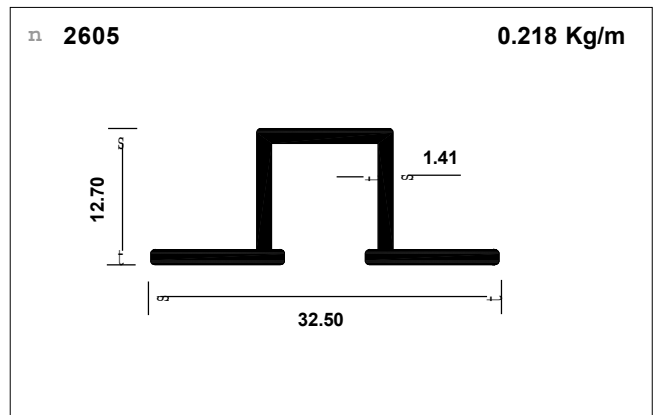
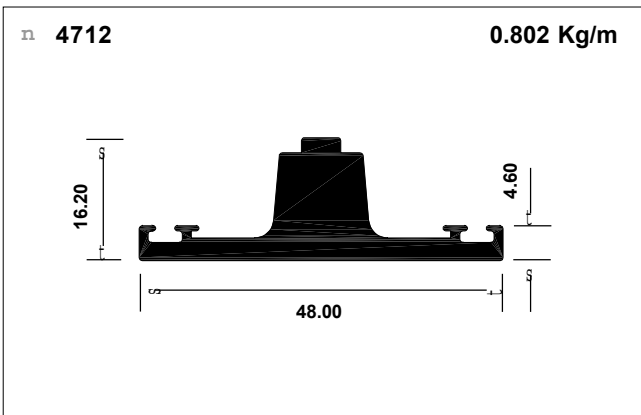
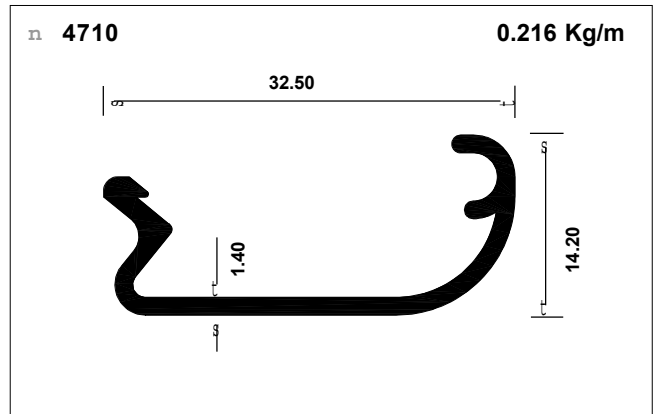
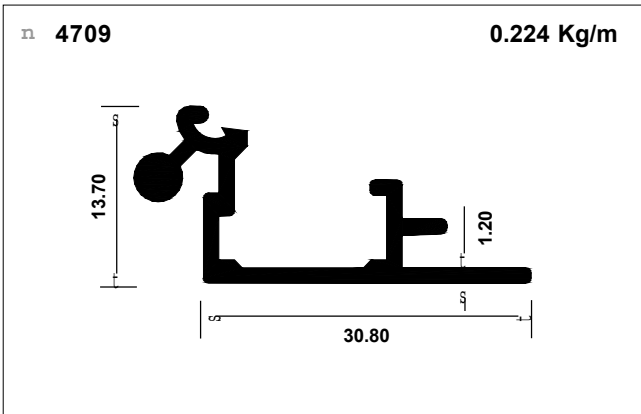

Truck body structurals

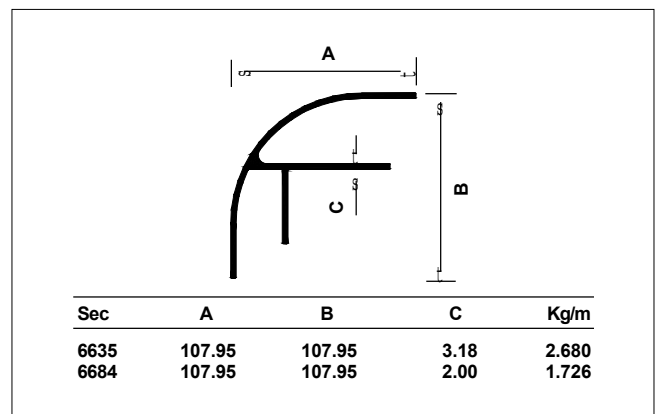
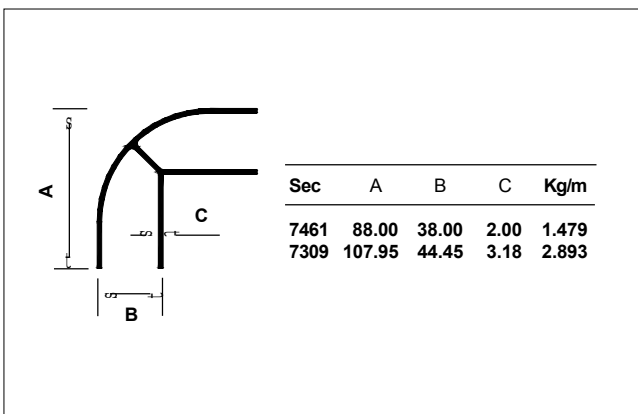
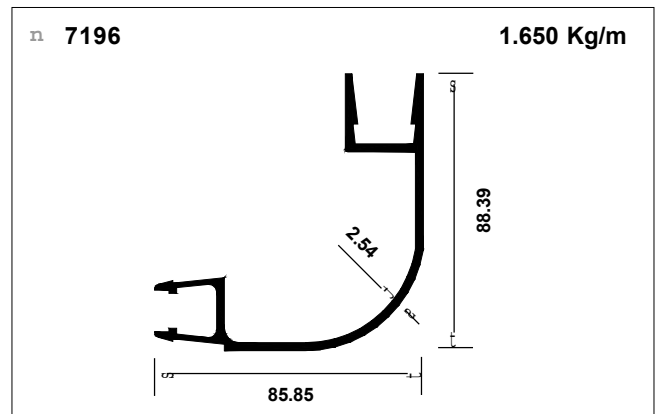
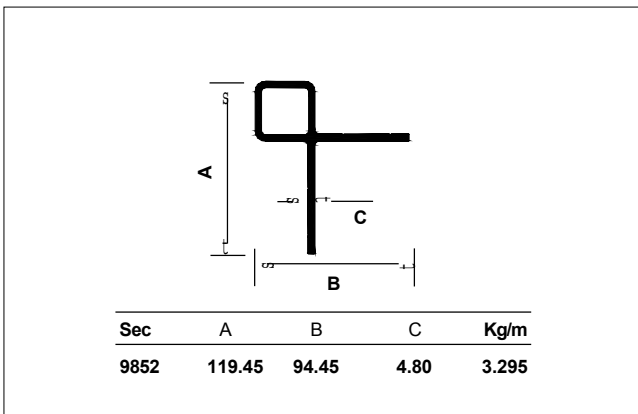
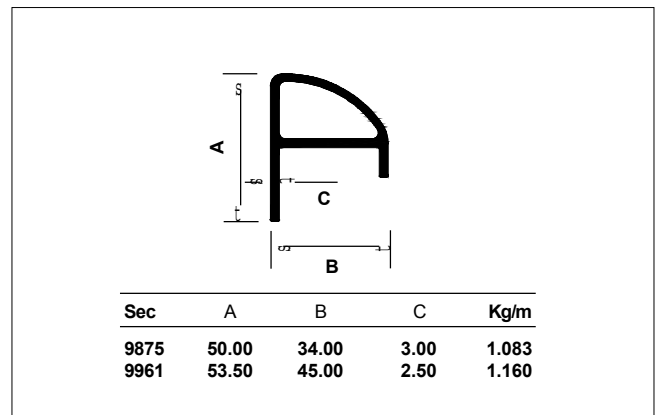
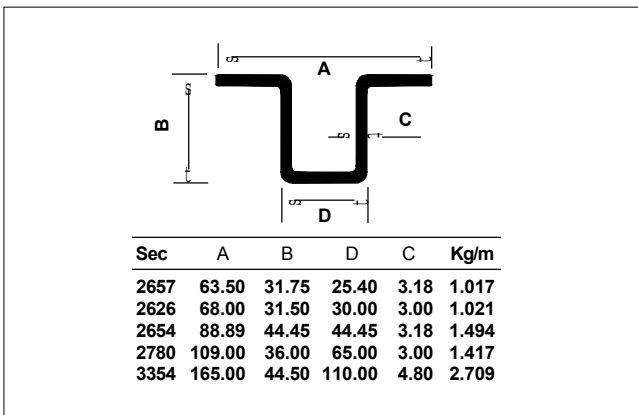
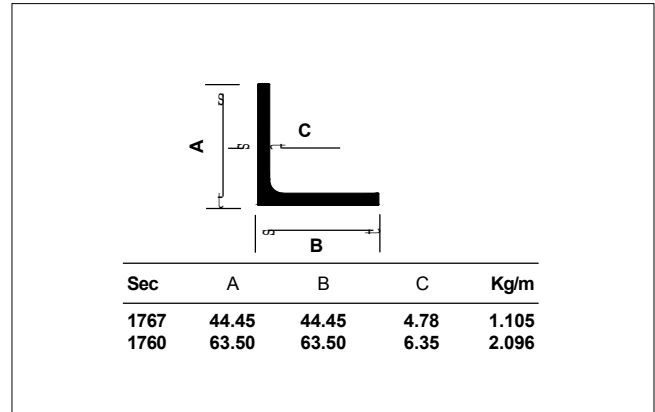
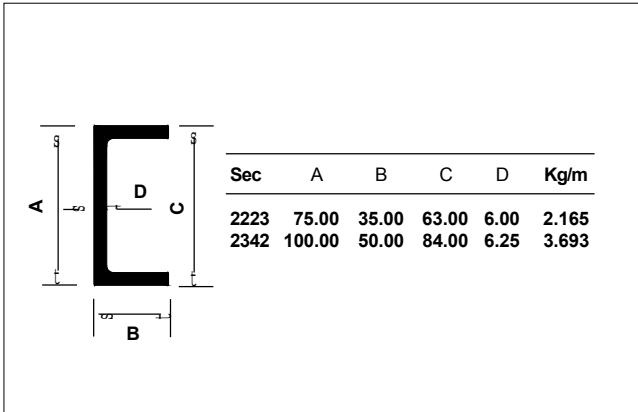

Truck body structurals

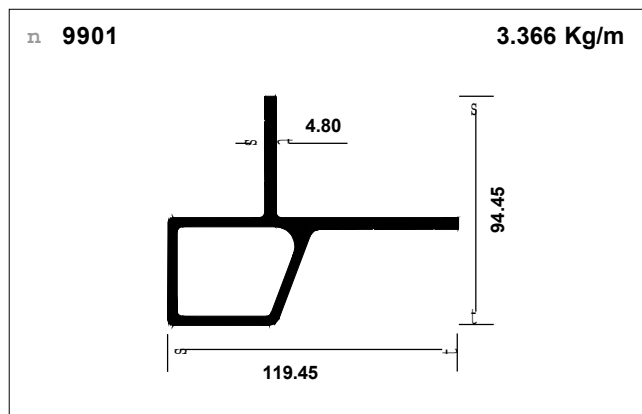
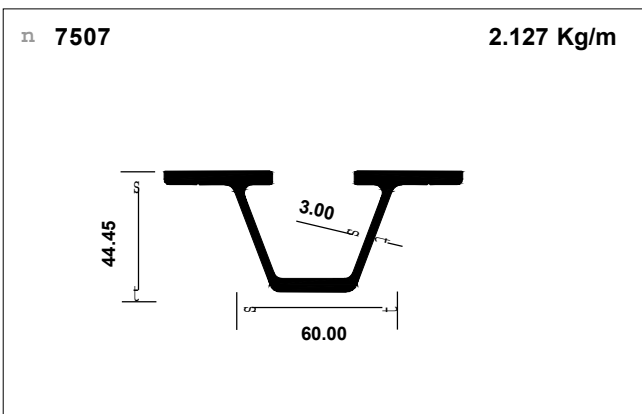
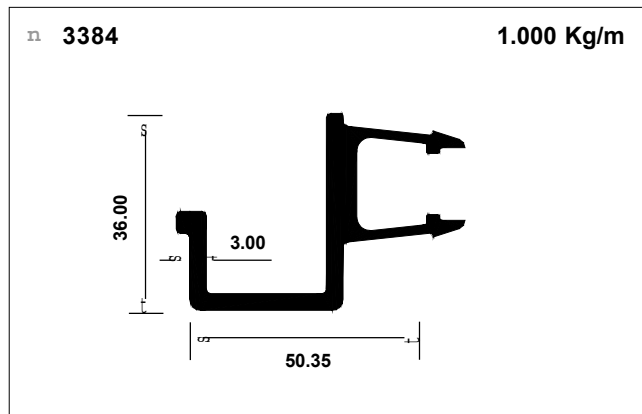
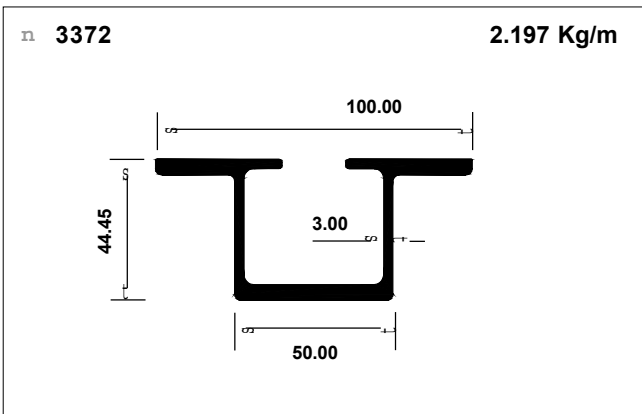
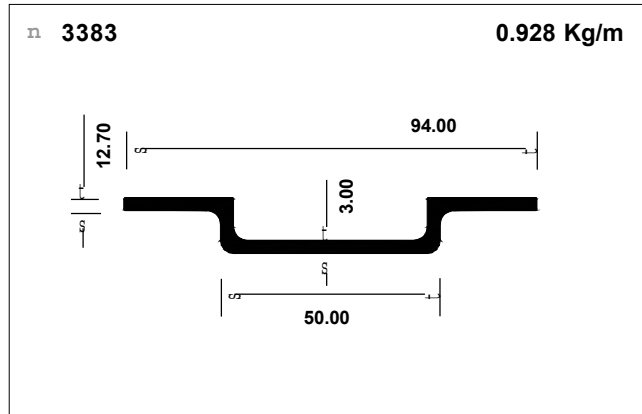
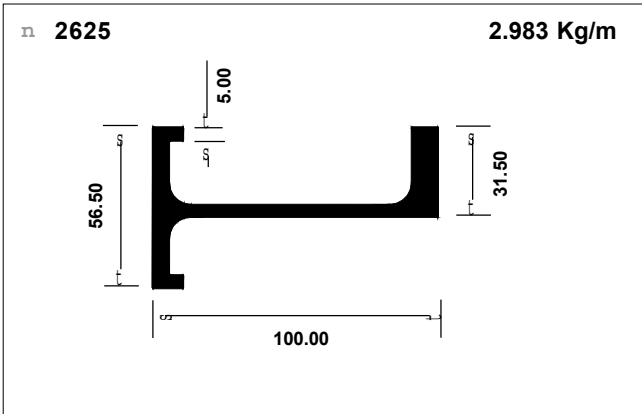
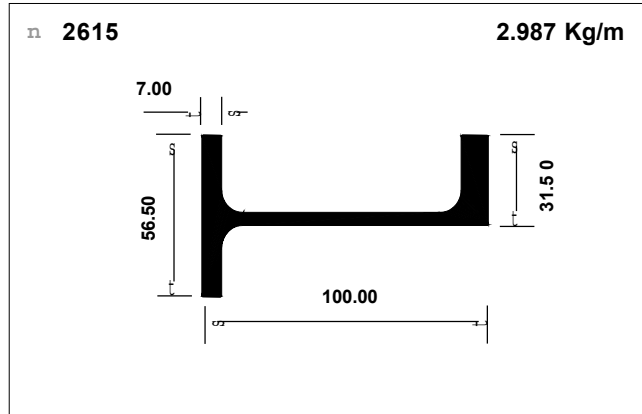
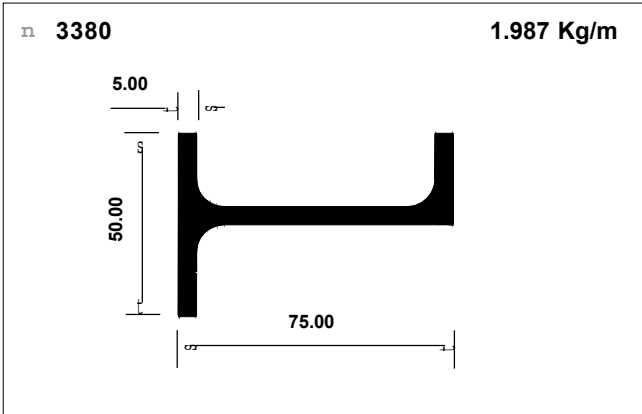



Truck body structurals

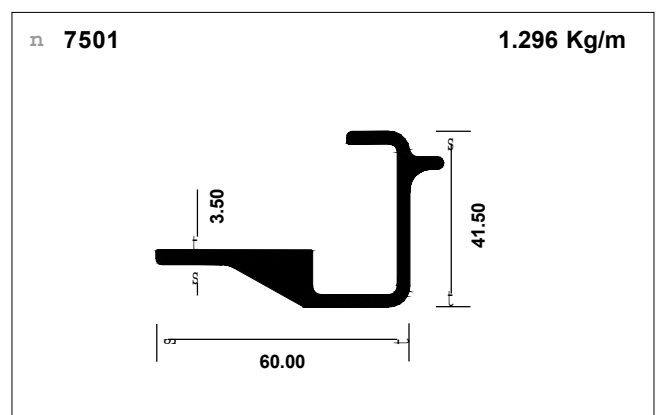
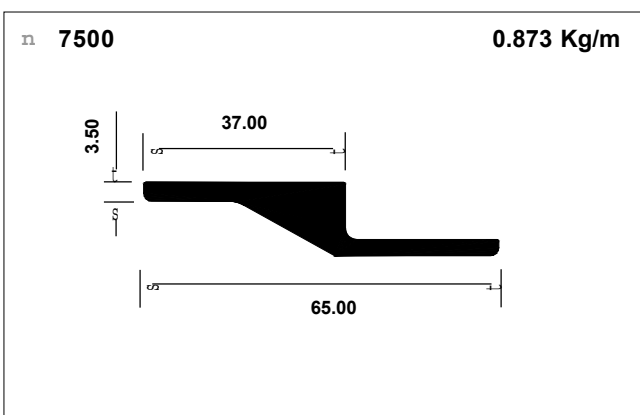
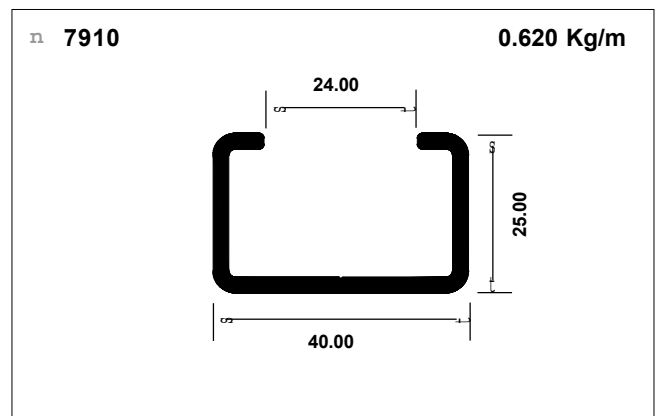
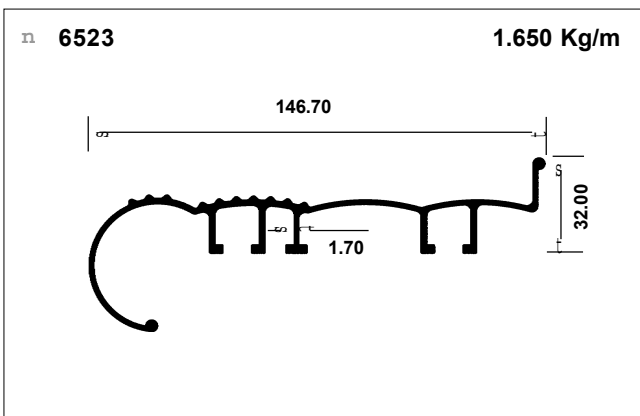
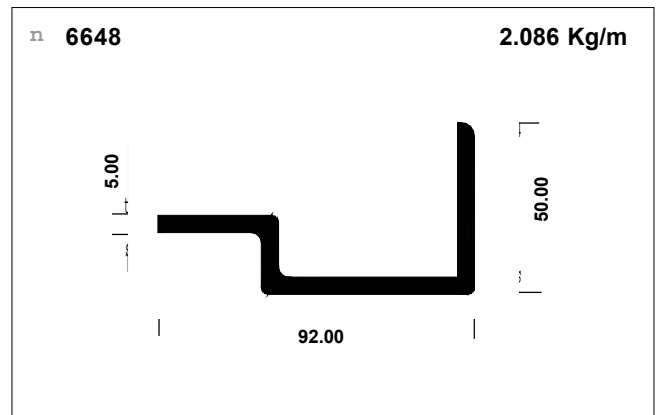
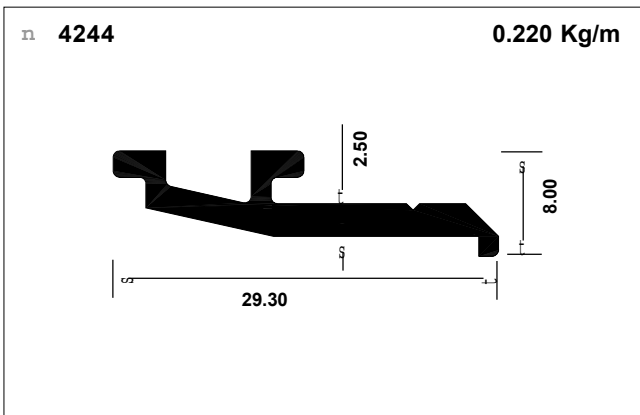
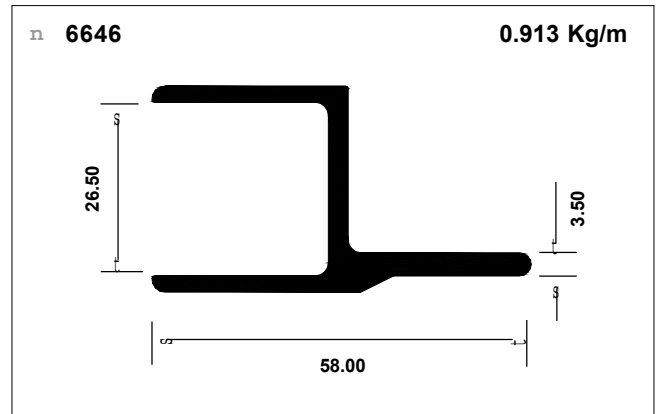
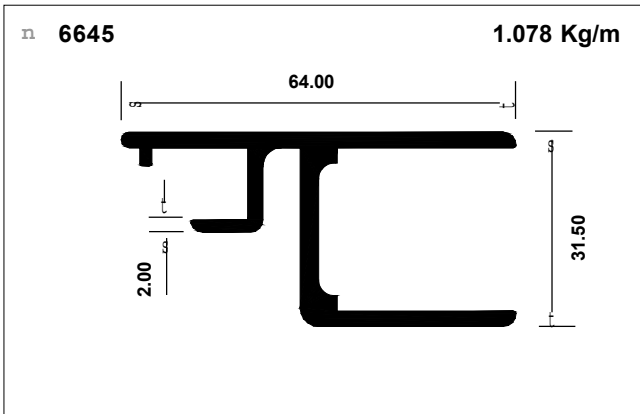

Truck body structurals

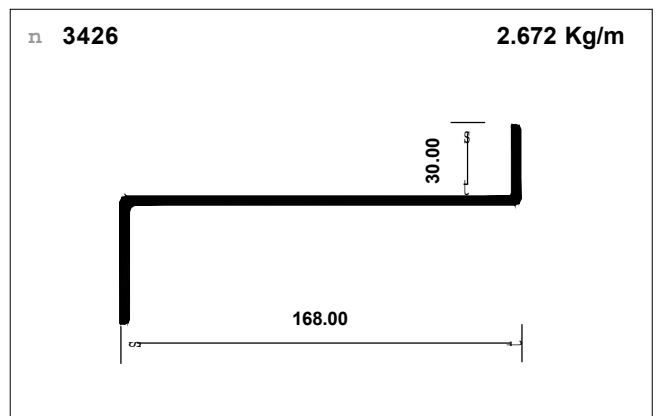
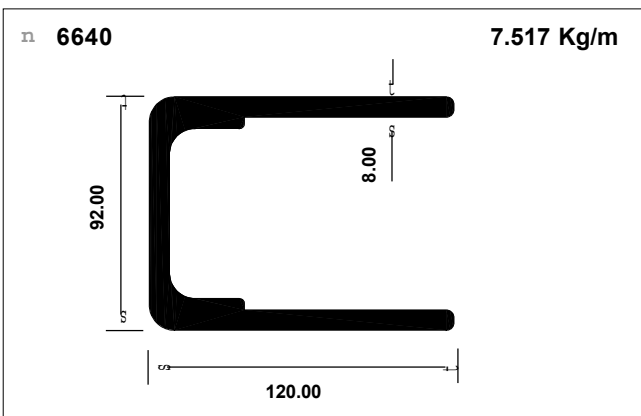
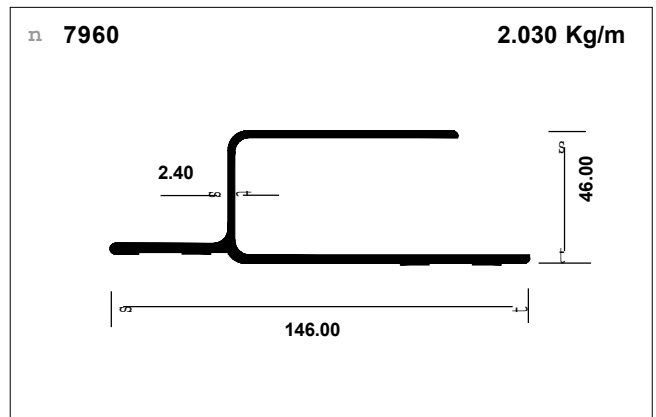
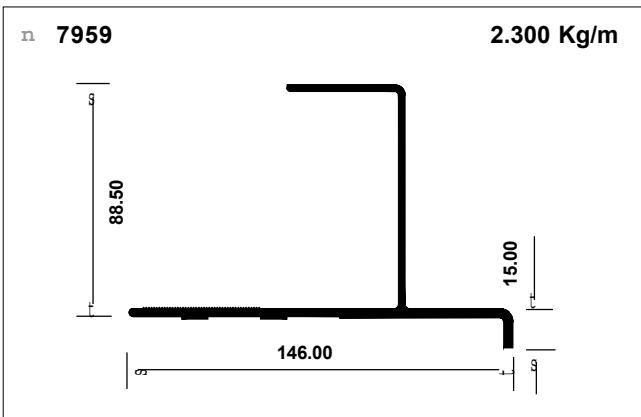
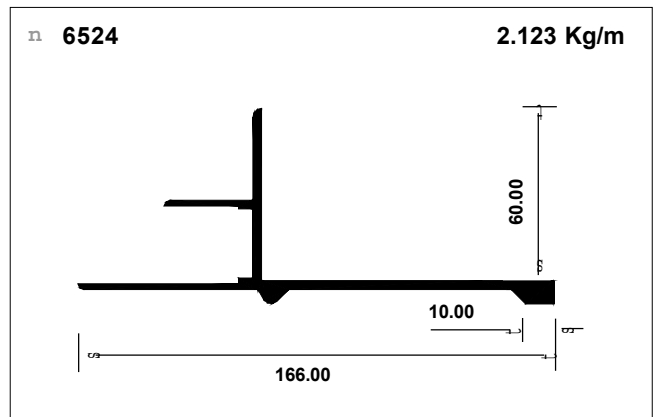
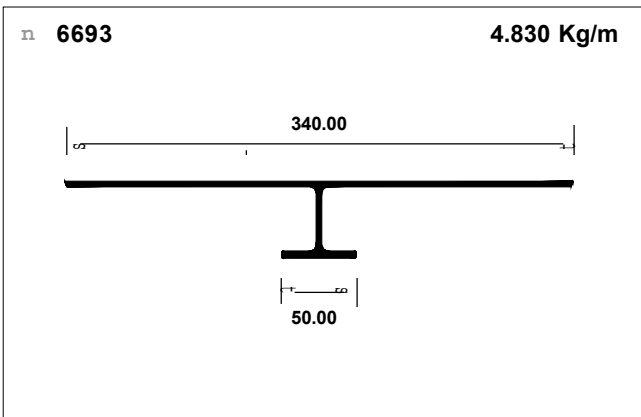
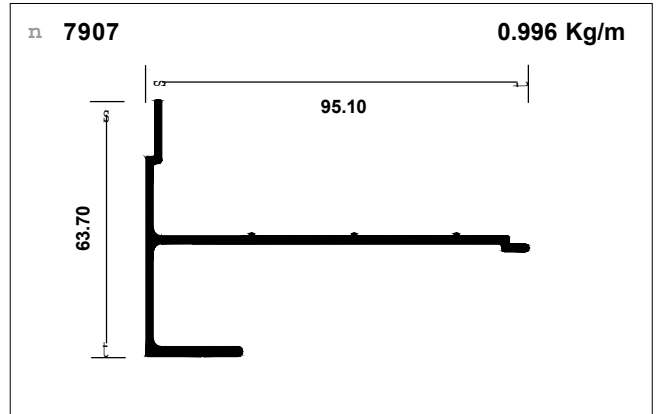
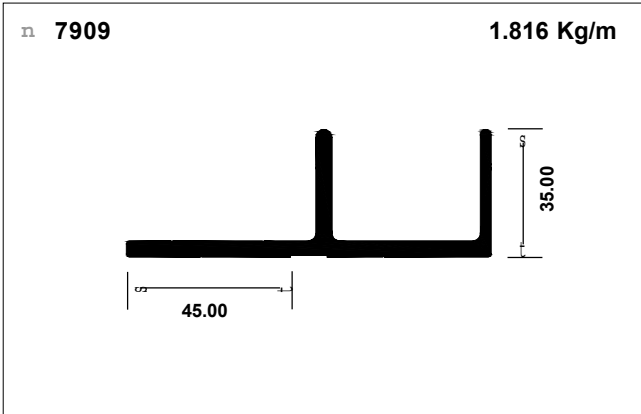

Truck body structurals

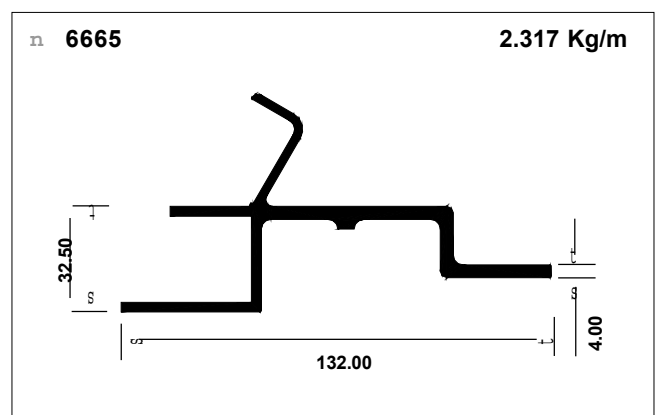
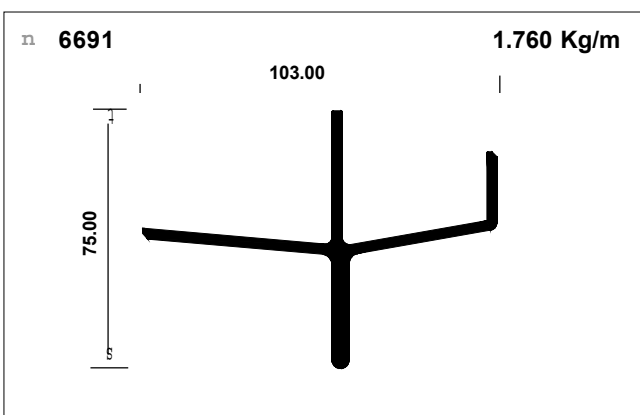
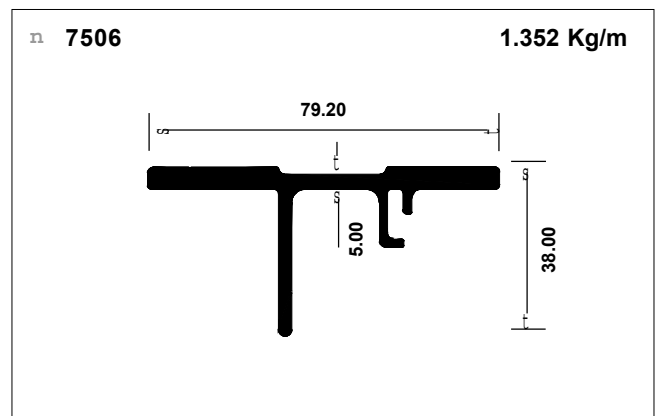
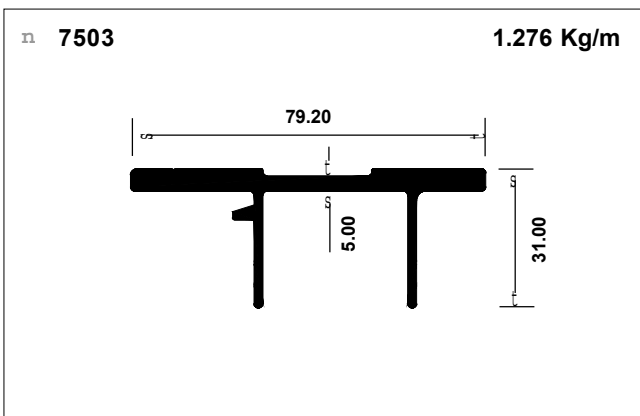
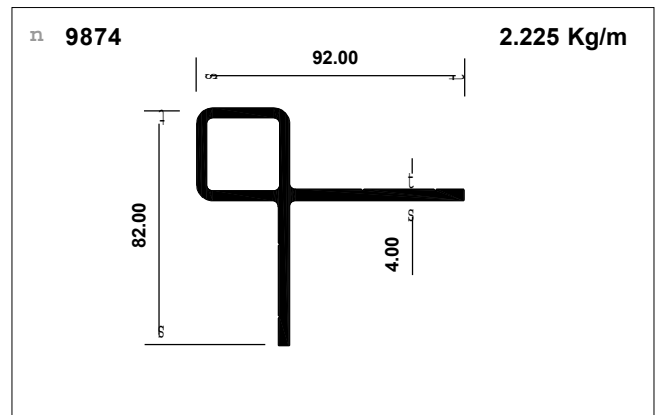
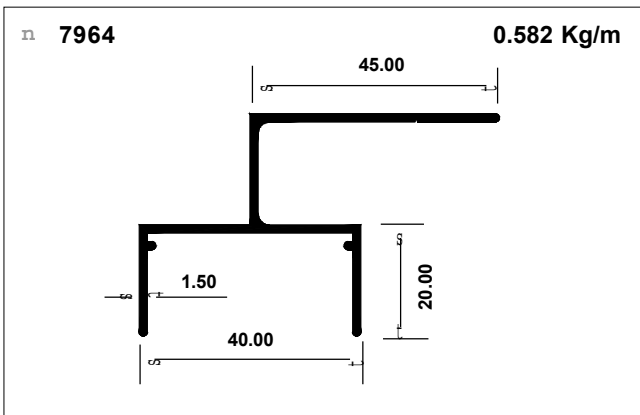
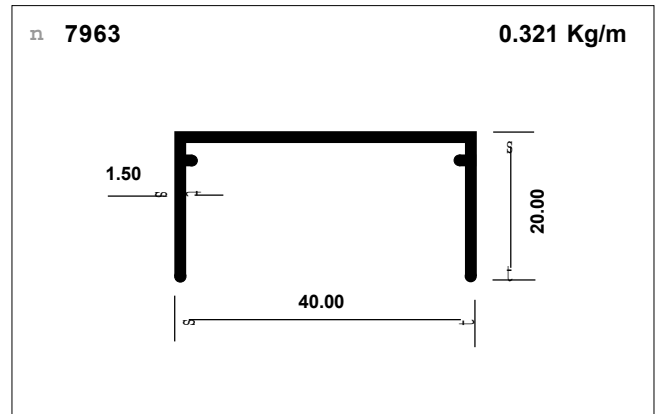
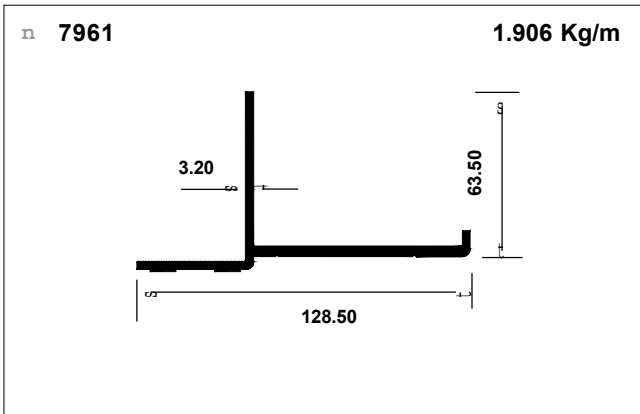

Truck body planks

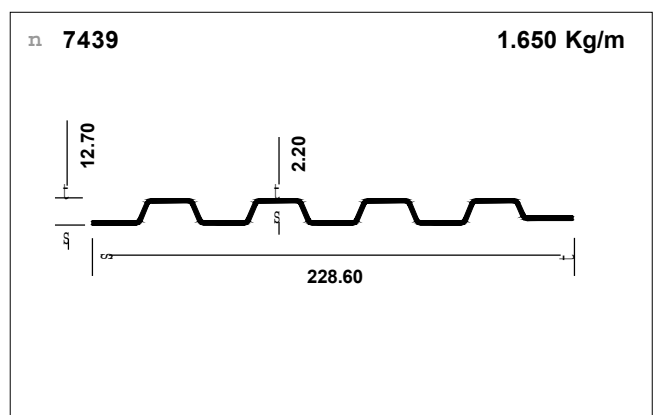
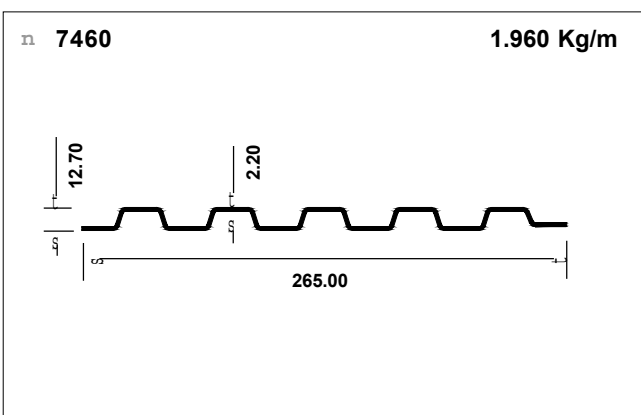
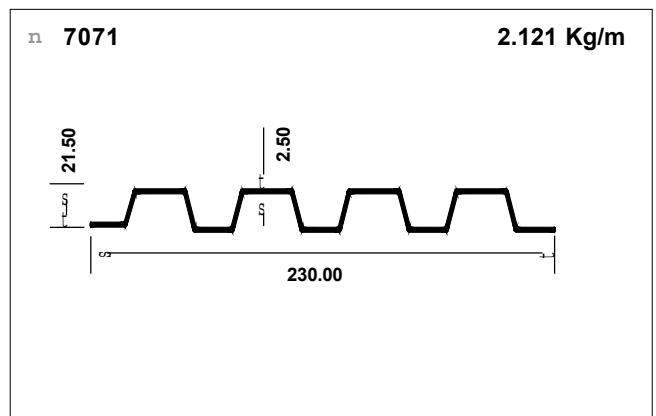
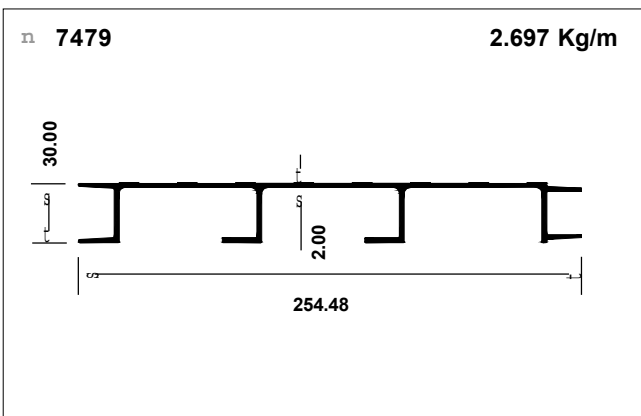
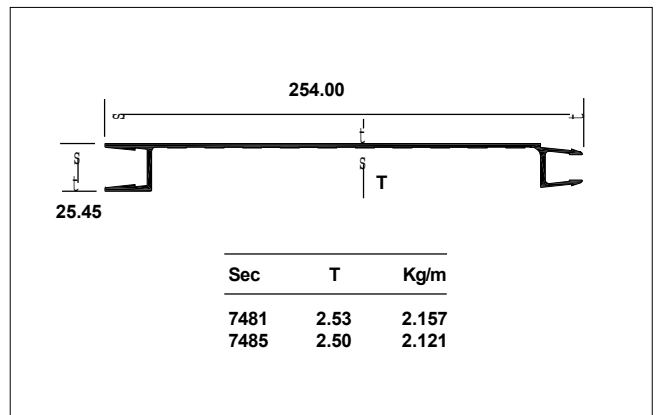
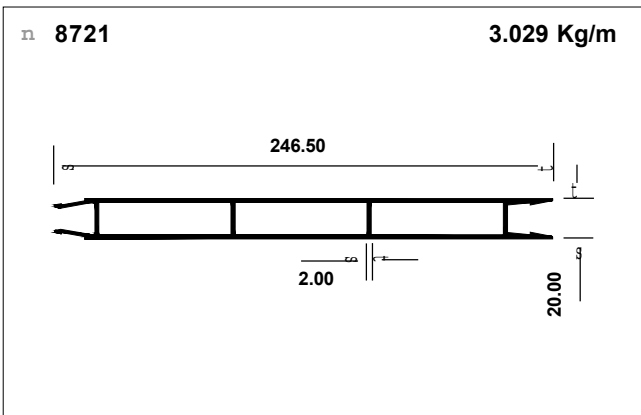
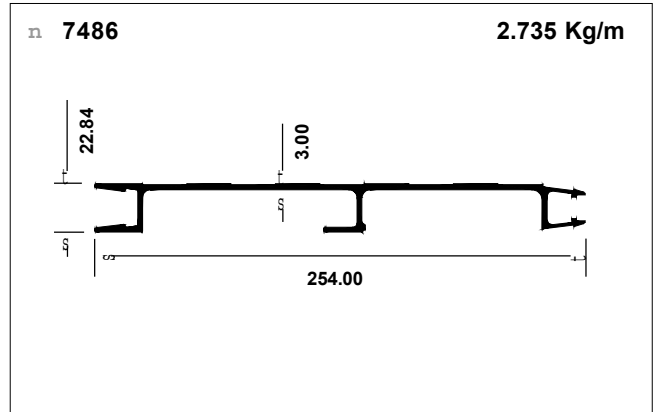
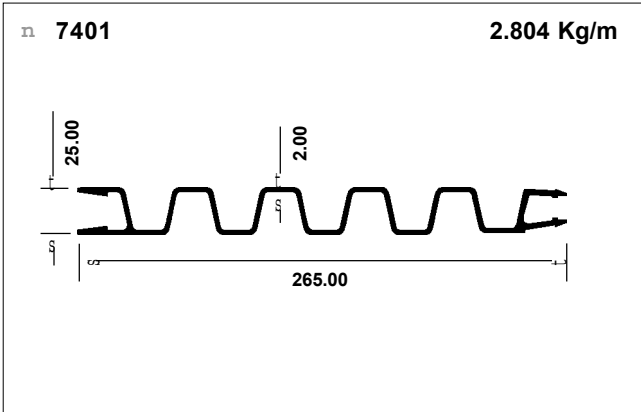

Rail coach windows

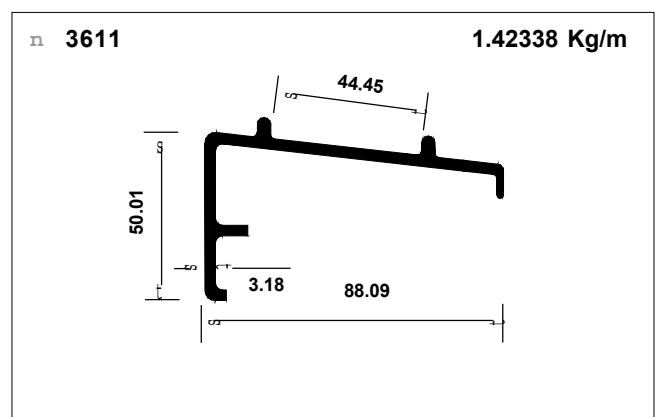
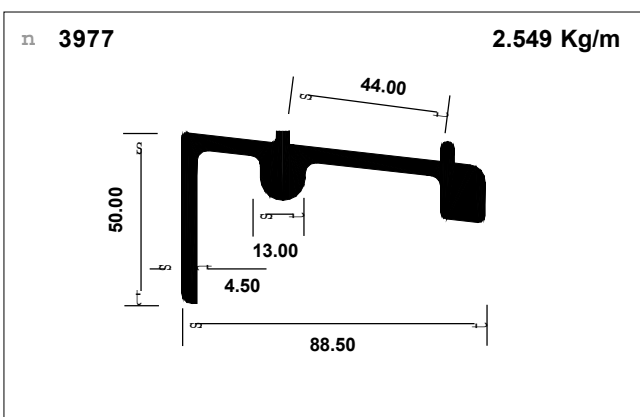
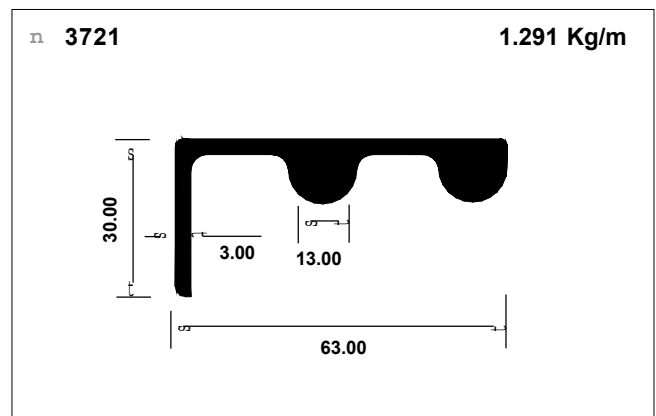
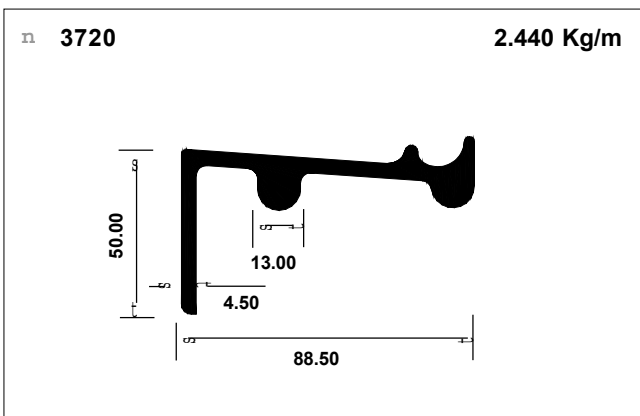
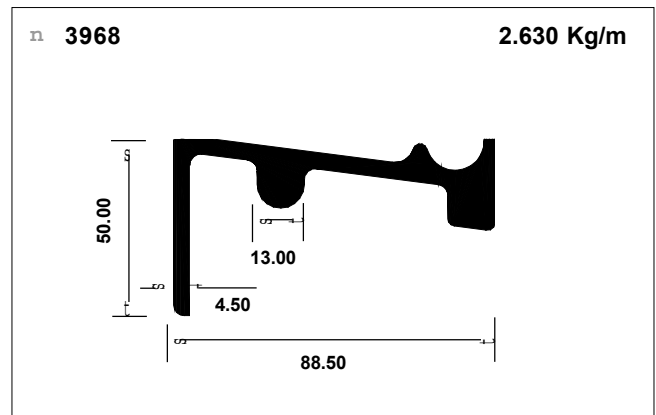
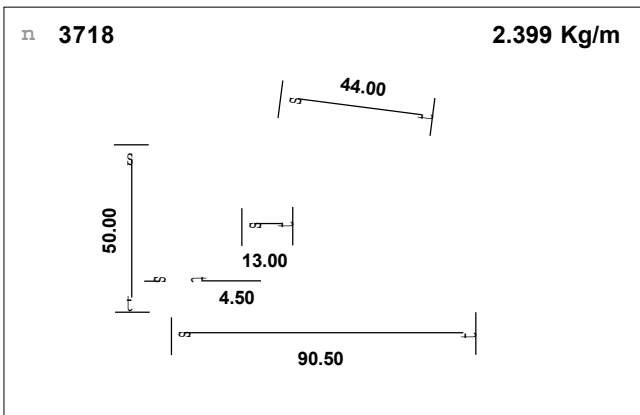
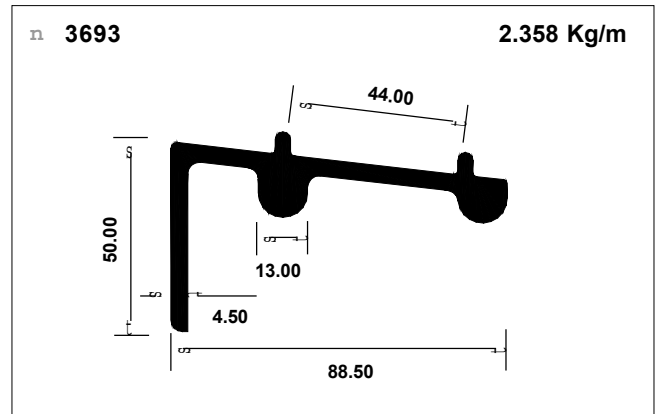
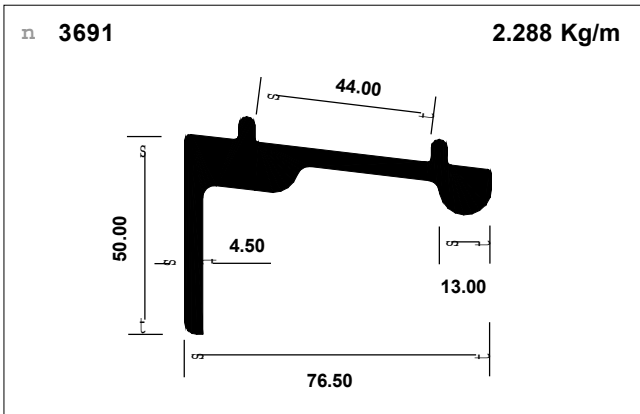

Rail coach windows

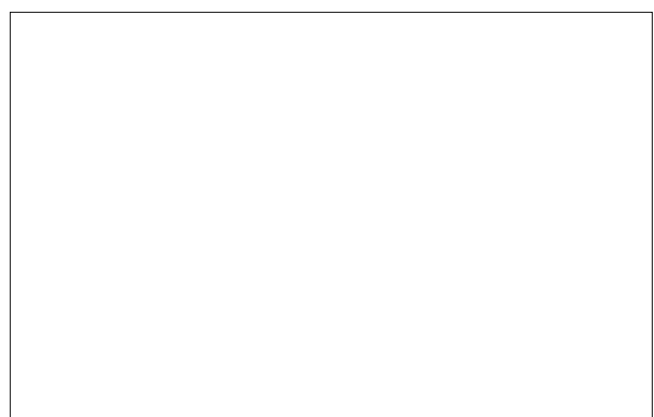
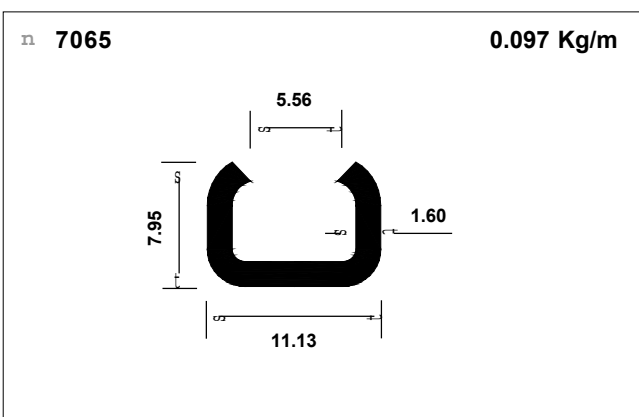
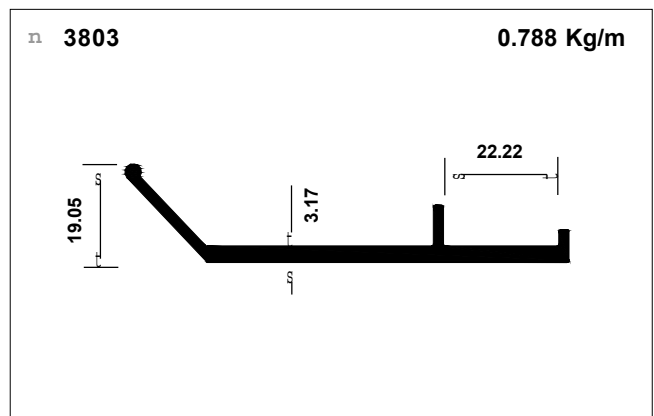
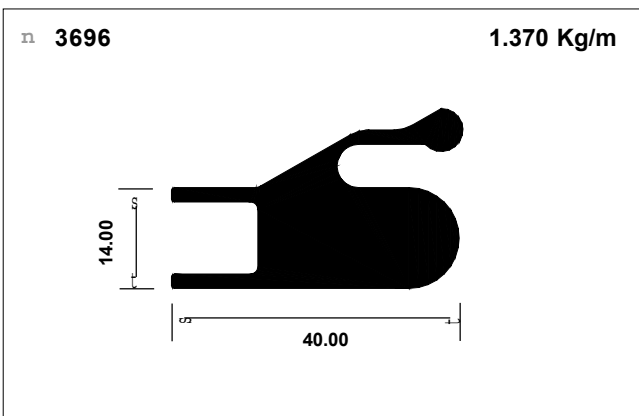
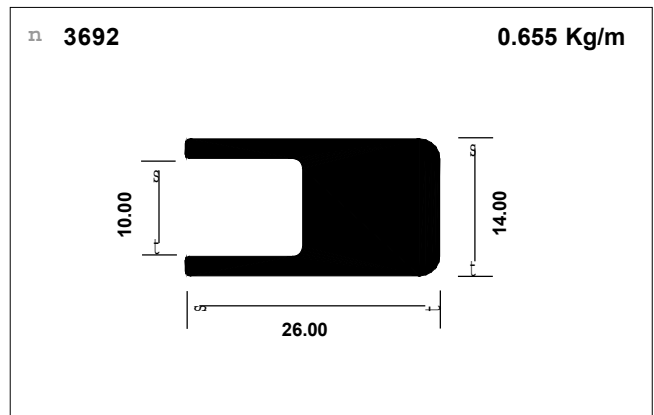
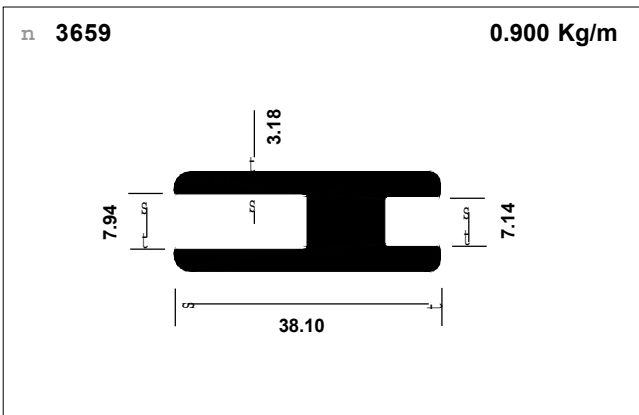
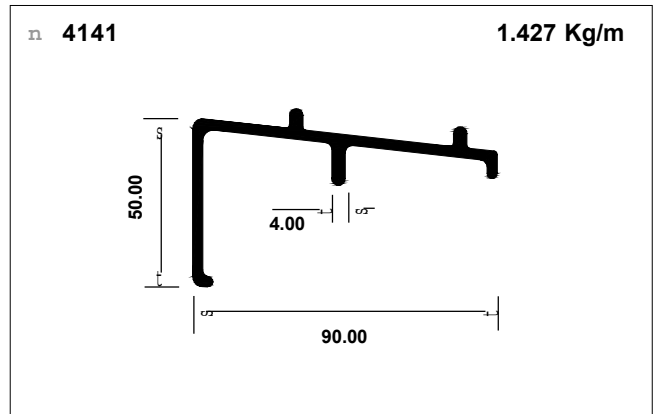
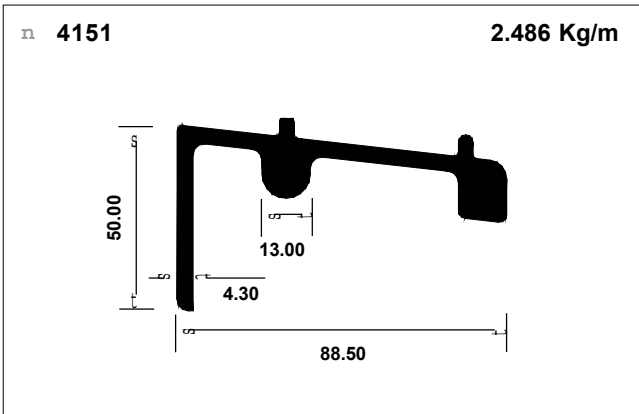

Rail coach windows

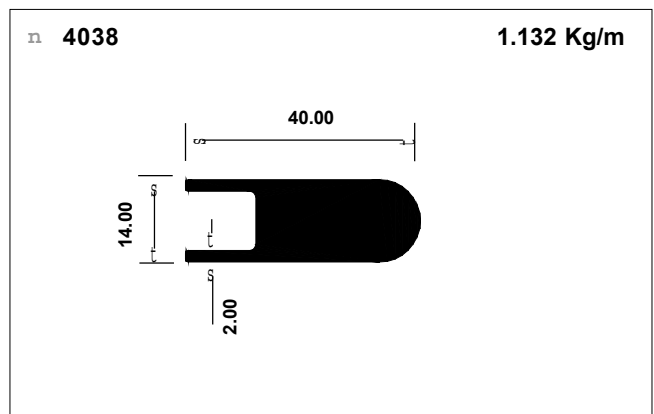
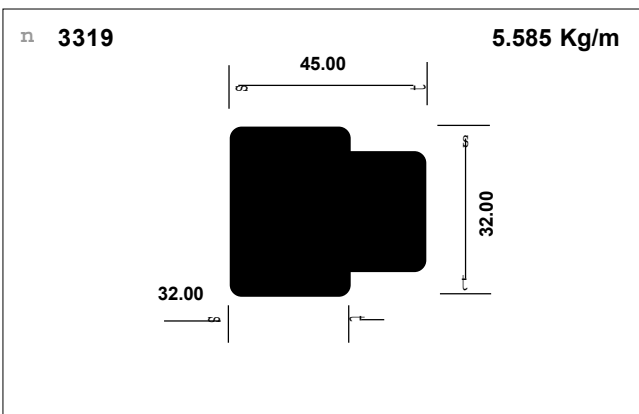
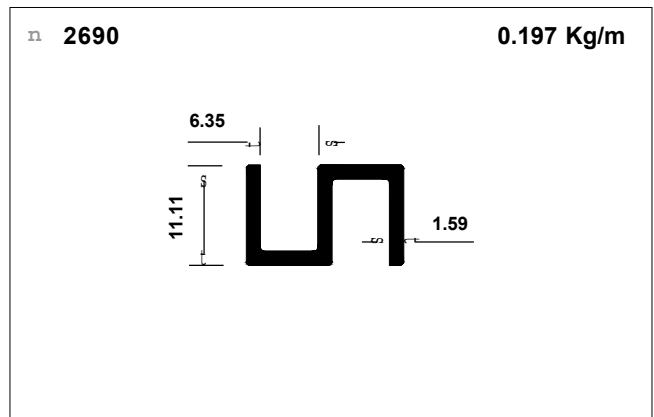
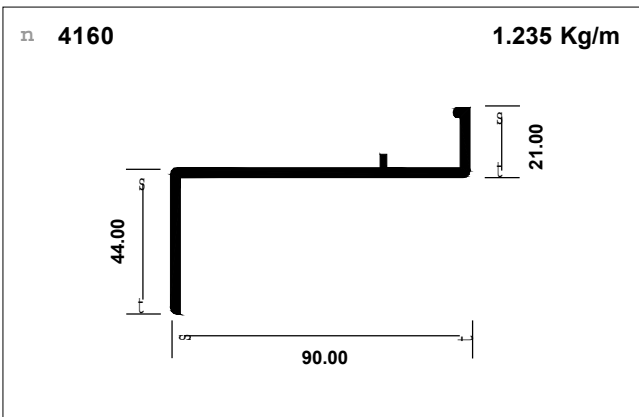
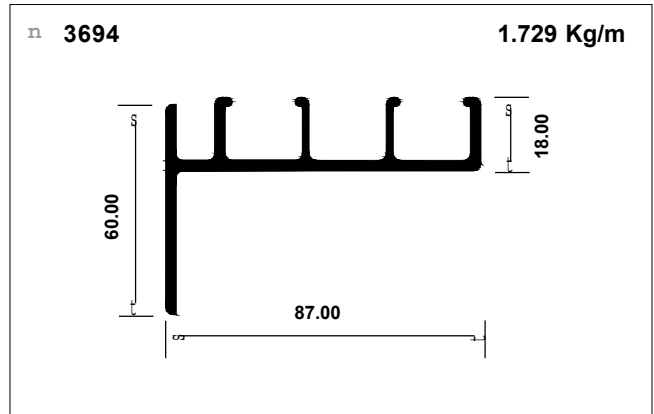
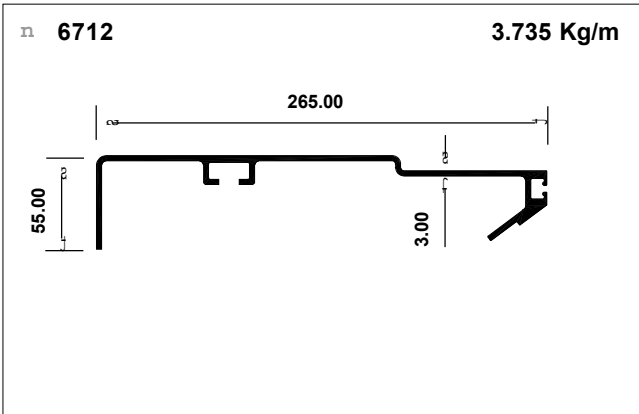
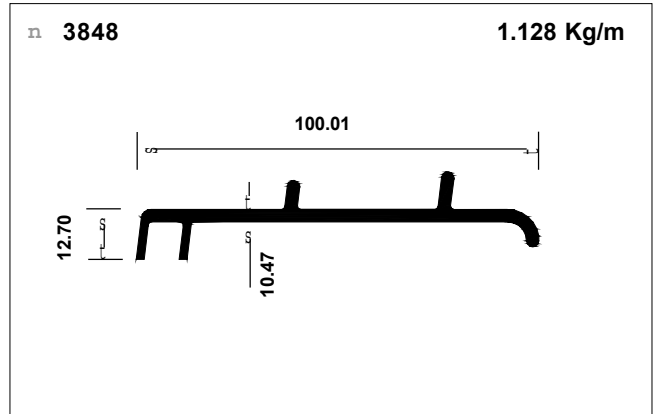
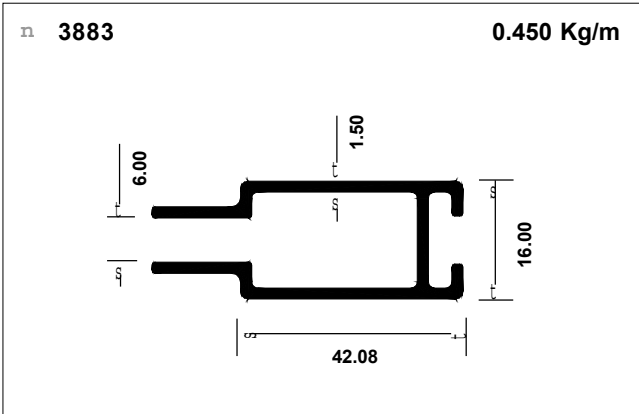

Rail coach

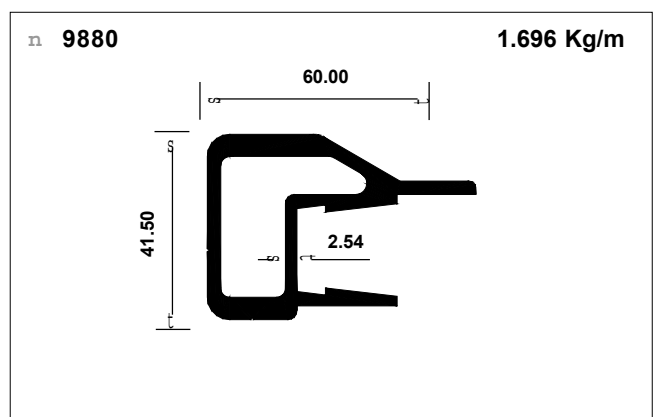
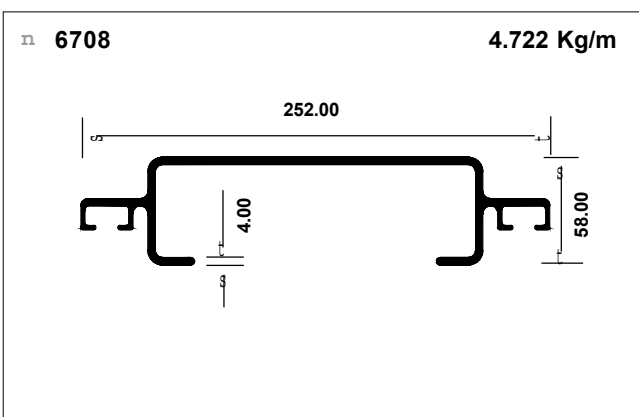
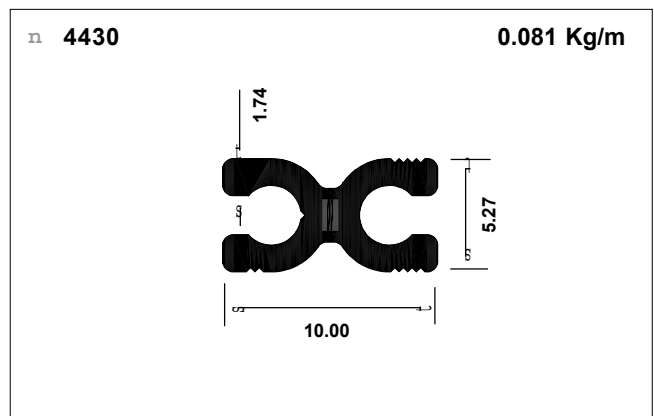
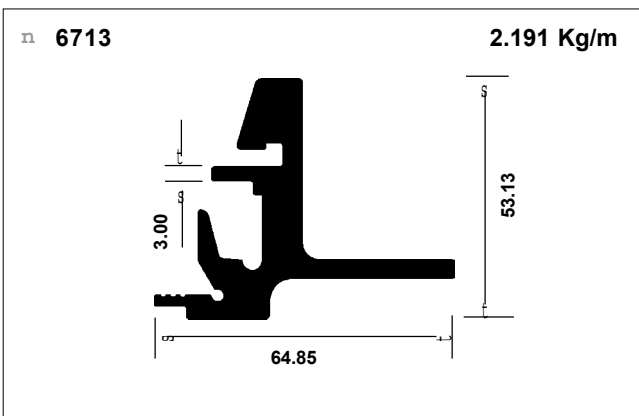
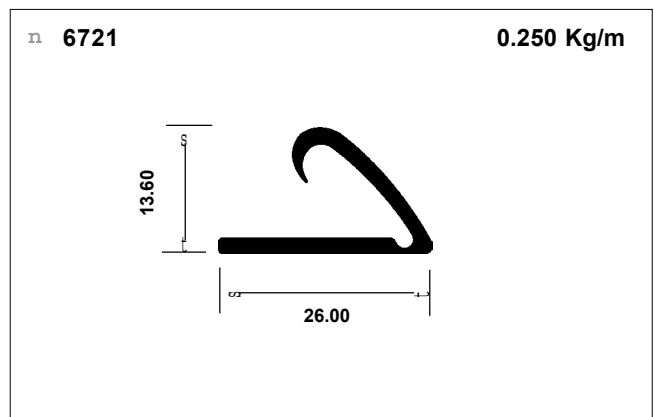
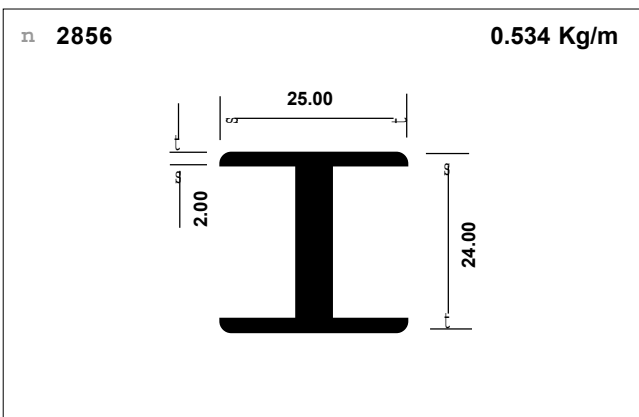
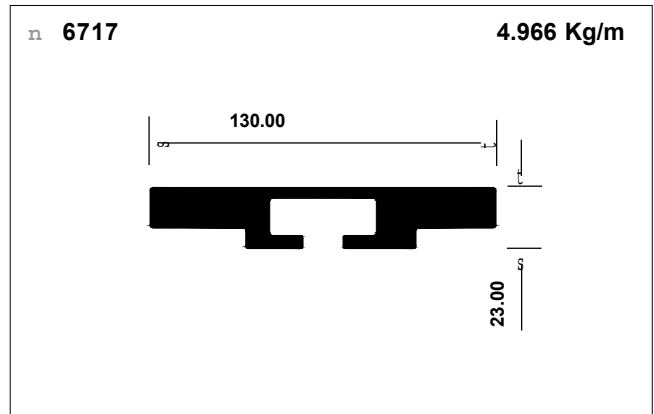
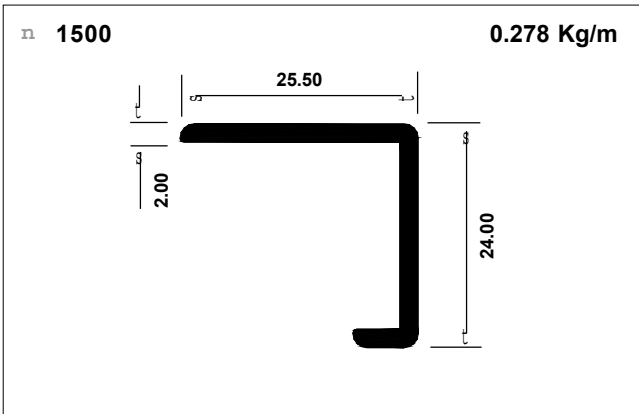

Rail coach

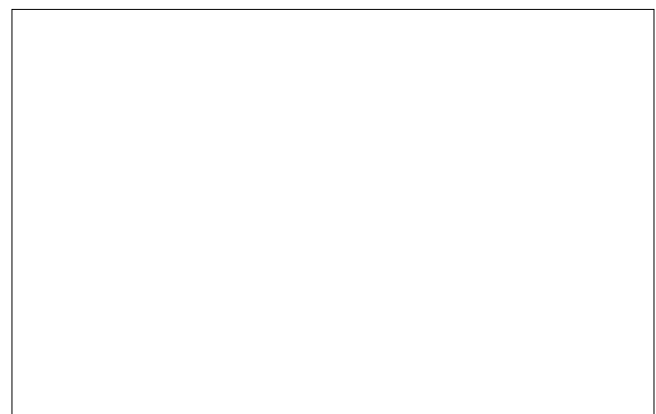
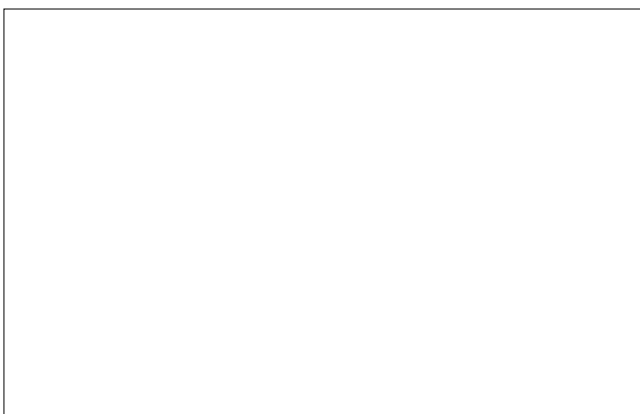
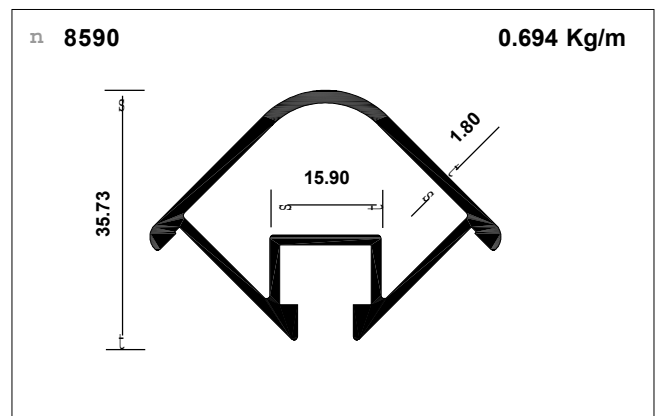
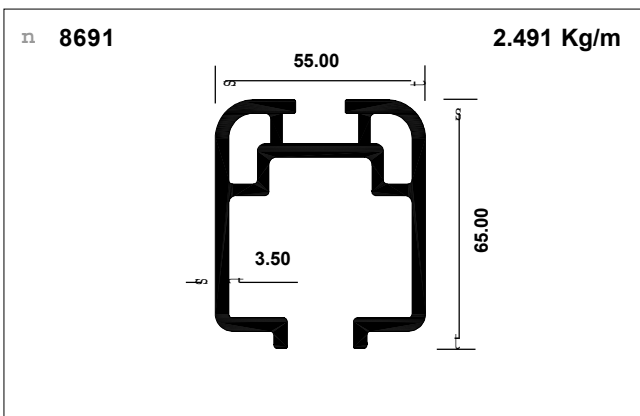
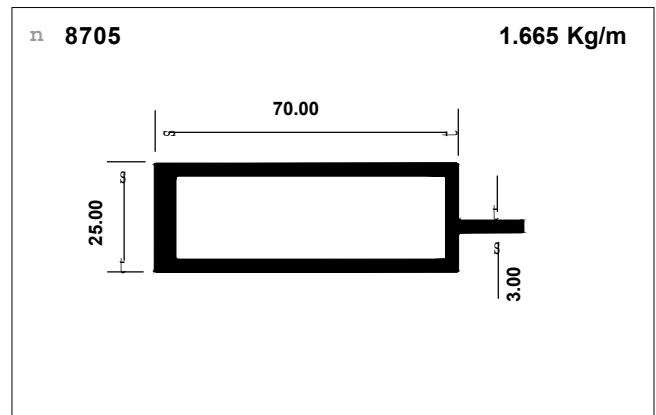
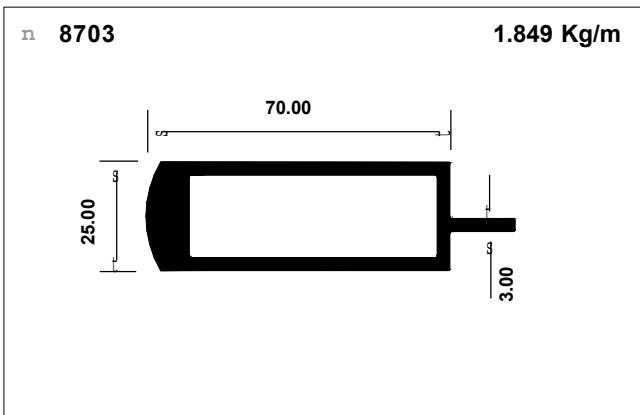
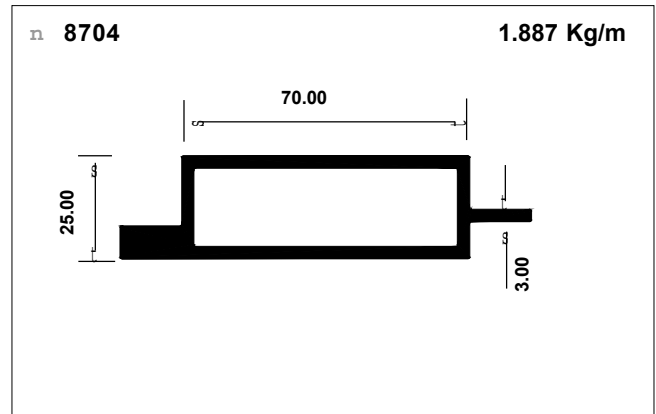
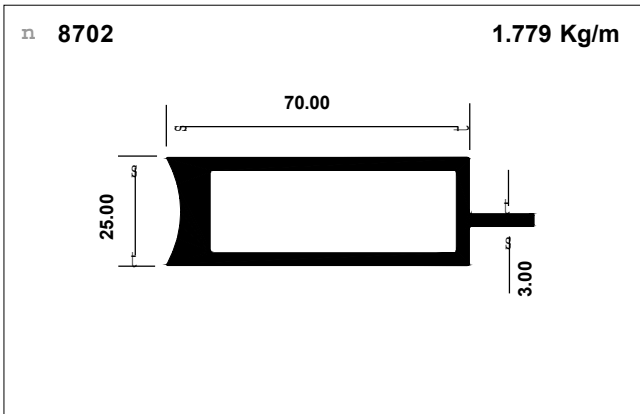

Rail coach doors

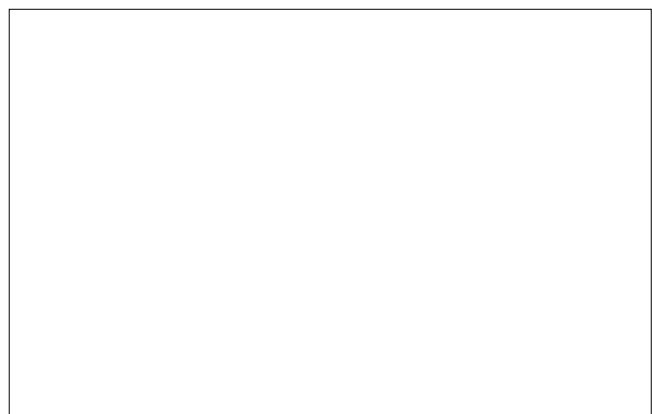
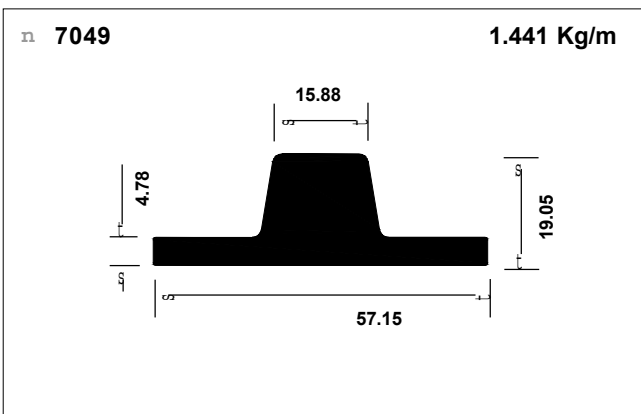
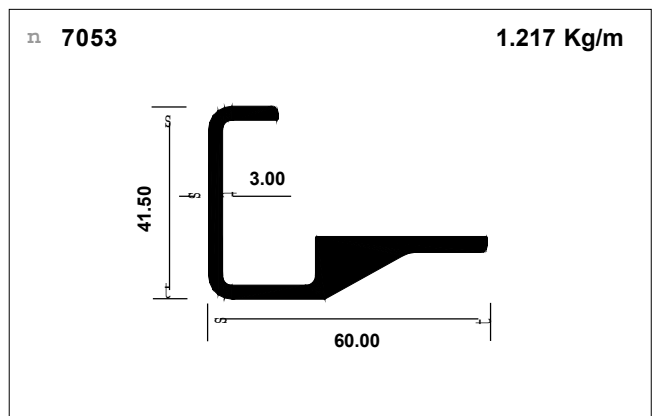
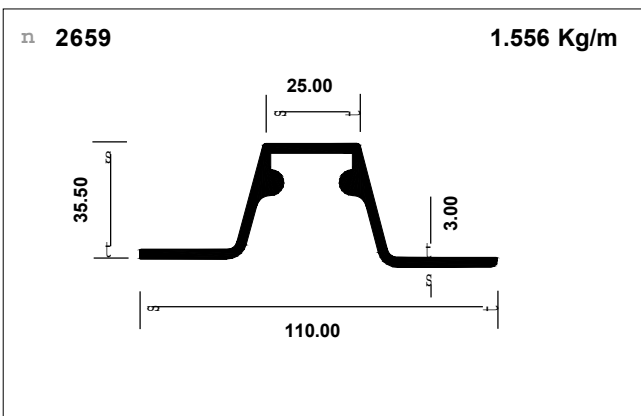
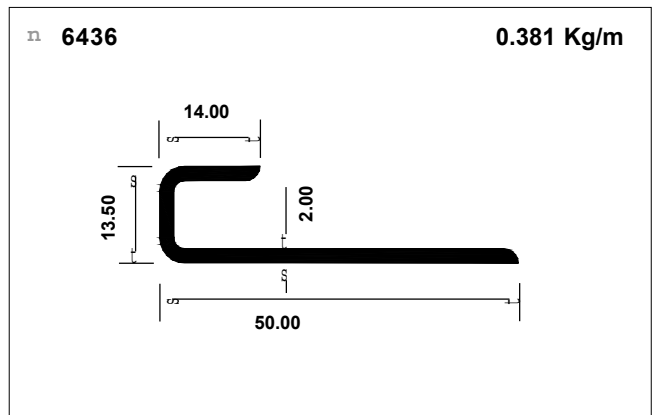
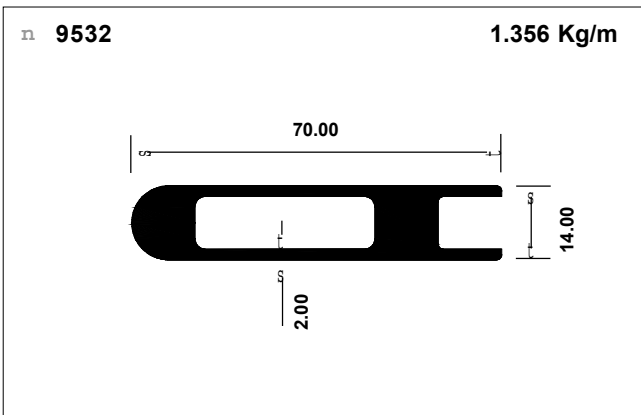
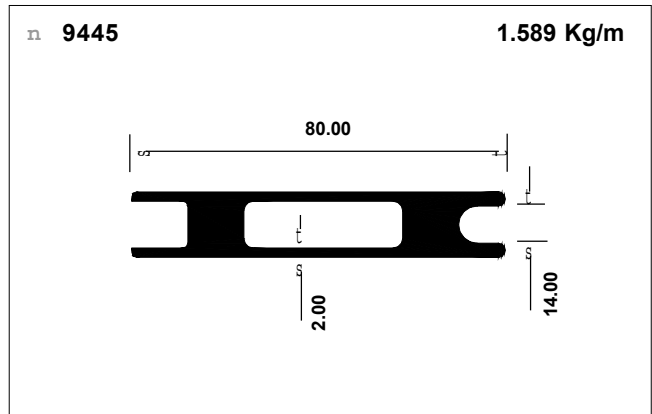
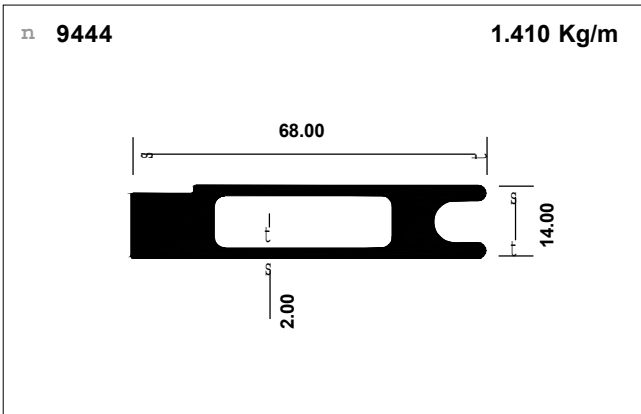

Miscellaneous

